

SECTION ONE

Lab Equipment: Using Your Tools

SECTION OVERVIEW

This section will be a review on lab equipment usage and safety precautions. The first step in validating any new design should be an accurate simulation. In this course, PSPICE will be used to simulate all the designs that will be used. In this section proper usage of the variable power supply, function generator and oscilloscope will be reviewed.

Objectives

- Be able to complete each lab in a safe manner.
- Be able to utilize the oscilloscope settings appropriately.
- Understand how to setup a lab power supply for single and dual channel supply.
- Be able to use PSPICE to simulate semiconductors and integrated circuits.

Materials

- Oscilloscope probe, BNC to alligator clips cable, test leads.
- Solder-less breadboard and jumpers.
- Your textbook, *Sedra and Smith*, for reference: Pages 174-182.

Design constraints

Box 1 lists the design constraints for the power supply. Keep these in mind as you complete each section of each lab. Each criterion must be met. On the Web-page, you can find the full project specification document. As you progress through the process of building your power supply, you need to use the specification document to build your system. Just like in any engineering job, you need to build to the specification. The project requirements are listed and explained in more detail in the specification.

- Two channels, one positive and the other negative, when referenced ground.
- Each channel must be able to supply at least 900mA per channel continuously, at voltages between ± 2 and ± 12 V.
- Current limiting circuitry for each channel, protecting above 1 Amp +/- 10%.
- Voltage ripple less than $0.75V_{p-p}$ in amplitude per channel, with both channels fully loaded to 900mA.
- External connections for leads and voltage adjustment.
- Easily accessible AC power switch.
- A clearly visible power indication light.
- Safely equipped with a cooling fan that should not normally be running at 70°F , but should reach rated speed around 95°F .
- Power supply assembled safely and with no electrical hazards, and utilizes a safety fuse.

Box 1: Power Supply Design Constraints

PRE-LAB

Nothing will be required for turn-in in Section One. If you would like to get started, start creating your net list for Part Six, (which appears later in this section). If you are not familiar with the PSPICE commands listed in Part Six, you can find examples in the [PSPICE reference document](#).

In future sections of this lab, you will be asked to design the circuit element prior to coming to lab. You should submit these sections in the format, as indicated by the project specification document. At the end of the entire lab, you will be asked to submit a fully-completed project specification document.

LAB

This lab is divided into six parts: **lab safety rules, cost analysis of parts, understand the oscilloscope and signal generator settings, power supply block diagram, and SPICE simulation of a full-wave rectifier.**

Part One – Lab safety rules

The most important component in any lab work is the ability to complete it safely. This means not only preventing harm to yourself or others, but also not damaging the lab equipment. The TA may ask you to leave the lab if your actions are not safe.

Make a note of the following lab safety rules:

1. **Power supply:** The power supply in this lab interfaces with the electrical system of the building. Any connections that are energized to 120 VAC must be covered with shrink wrap before plugging in the power cord. This is especially important in Section Two.



The TA may ask that to see that the circuit is safe before it is energized.



Even though later labs will use low voltage DC, these may still contain shock hazards.

2. **Filter Capacitors:** The filter capacitors used in Section Two are only charged to 18 VDC or less. However, their high capacity gives the potential for a significant source of current long after the power supply is unplugged.



Always treat a circuit as if it were energized! Never work on a power supply while it is plugged in.

Lab safety rules (Contd.)

3. **One-Hand Rule:** A very important rule to follow is often called the “one hand” rule. This means you never work on an electrical system with more than one hand. Only using one hand precludes the possibility of a path of current from one hand to the other, by way of your heart. Your TA will remind you of this rule if you do not follow it carefully.

Causing parts to get hot; emit smoke, or even cause loud “bang” noises are all a part of learning. Some mistakes will happen and you may even destroy a transistor. This is all part of the learning process.

Part Two – Cost analysis of parts

An important aspect of an engineer’s job is being able to create a design that not only meets the design constraints, but also does so with minimal cost.

In this course, you will be required to turn in schematics of your final design, along with a tally of the parts and the cost of these parts. Any circuits built for extra credit will not count towards the total cost of your design. The cost analysis is part of your project specification document and should be neatly integrated into the document under Section Eight.

Groups that meet all the design constraints and have the cheapest power supplies will be awarded extra points.

Part Three – Understand the oscilloscope and signal generator settings

It is imperative that you understand how to use an oscilloscope properly and in a timely manner. Familiarize yourself with: AC and DC coupling modes, “Measure” features, and probe compensation. In this section, you will prove that you know how to calibrate probes, and measure AC and DC components properly as well.

In order to understand the oscilloscope settings, follow these steps:

1. Plug in the probe, compensate it, and make sure you are in the proper gain mode (10x, 100x, etc.).
2. Create a 60 Hz sinusoidal AC signal of 200 mV amplitude, with DC offset of 1V with your signal generator.
3. Use the oscilloscope to measure the signal generator output. Measure the offset and AC signal separately, (i.e. AC and DC coupling modes).
4. Save the output with TekVisa (OpenChoice) to your computer. Plot the AC and DC recorded data separately. Show the peak and frequency (period) clearly.
5. Each lab member should calibrate their probe.

<http://classes.engr.oregonstate.edu/engr/winter2002/engr201/engr201tds210.html>



It is important that you understand the operation of an oscilloscope and be able to use it properly. You will frequently use an oscilloscope in *Signals and Systems II* (ECE 352), *Microprocessor System Design* (ECE 473) and in the Senior Design Project.

Part Four – Power supply block diagram

The power supply that is built in this course can be described using a functional block diagram, such as the one shown in Figure 1. In any complex engineering design, functional diagrams are important in breaking up the overwhelming design into small manageable pieces. Figure 1 is a simplified block diagram of the power supply project.

With respect to Figure 1, note the following:

- This is an example of how one would specify each of the signals entering or leaving such a block.
- The design starts at the power cord and ends at the voltage regulators.
- Internal to the supply, there are many different sub-systems that perform a variety of different tasks.
- During the course of this term, you will be designing circuits that fulfill the requirements for all of these blocks.

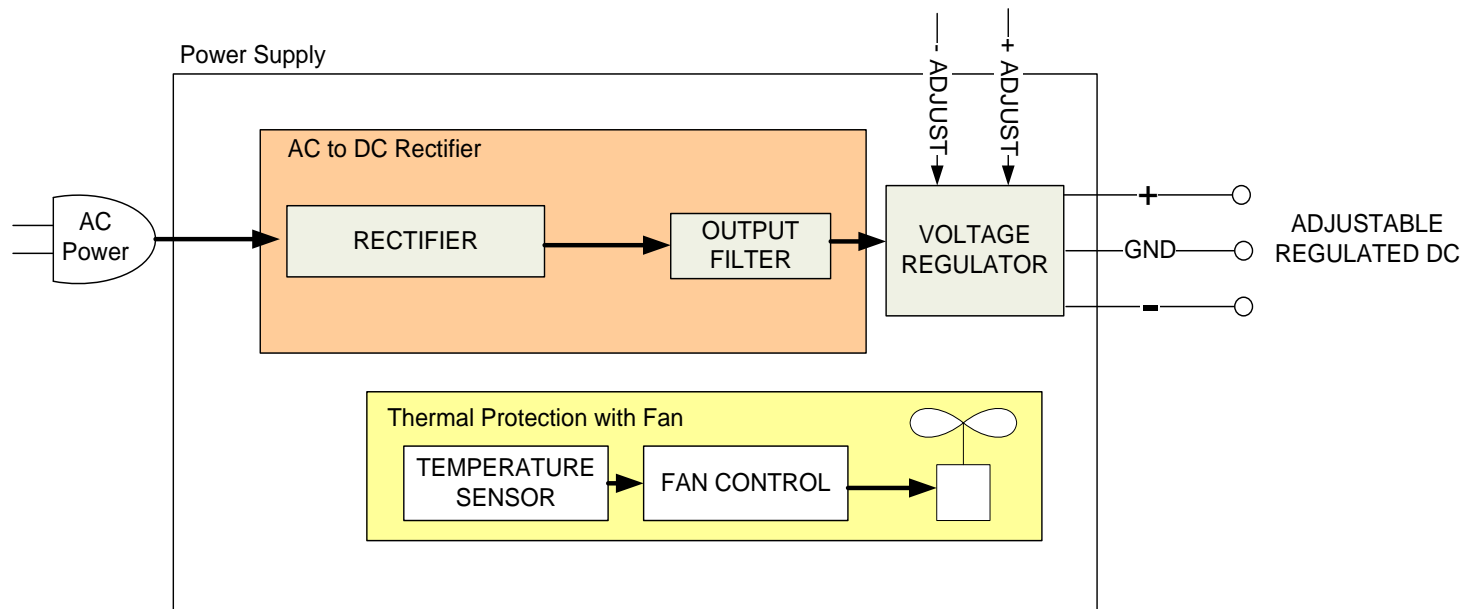

Figure 1: Simplified Block Diagram for the Power Supply

Section One: Lab Equipment (Using Your Tools)

The following table (Table 1) shows the various external connection specifications for the power supply.

Name	Direction	Description
AC Input	Input	Frequency: 60Hz Voltage: 120VAC Maximum Current: 0.5 Amps
Positive Voltage Output	Output	Voltage Range: 2 to 12V Max Current @ All Voltages: 0.9 Amp Current Limit: 1 Amp +/- 10% Maximum Ripple: 0.75 V _{PP}
Negative Voltage Output	Output	Voltage Range: -2 to -12V Max Current @ All Voltages: 0.9 Amp Current Limit: 1 Amp +/- 10% Maximum Ripple: 0.75 V _{PP}
Positive Supply Over Current Indicator (optional)	Output	Turn On: 1 Amp +/- 10% Indication: Visual or Audible
Negative Supply Over Current Indicator (optional)	Output	Turn On: 1 Amp +/- 10% Indication: Visual or Audible
Positive Voltage Adjustment	Input	Adjustment Method: Dial/ Potentiometer Full Scale: Single Turn
Negative Voltage Adjustment	Input	Adjustment Method: Dial/ Potentiometer Full Scale: Single Turn

Table 1: External Connection Specifications for the Power Supply

Part Five – SPICE simulation of a full-wave rectifier

In the *Introduction to Electrical and Computer Engineering: Concepts* class, (ECE 112), you would have learned to *create SPICE net lists*. In this lab, you will need to be able to *create and read those net lists*. Refer to *Appendix A* for information on PSPICE net lists, models, and simulations.



The name “SPICE” is a generic term to describe a circuit simulation program. Many types of SPICE programs exist, among which PSPICE and HSPICE are most commonly used. In this lab, you will be using PSPICE.

You could create a .cir file by hand and not depend on the schematic entry tool. Open the .cir file with the “PSPICE AD Student” program to simulate your circuit.

As you know, a diode only has two terminals, making it an easy device for which to create a net list entry. Simulate the circuit, as shown in Figure 2, using the 1N4004 model for the diodes.

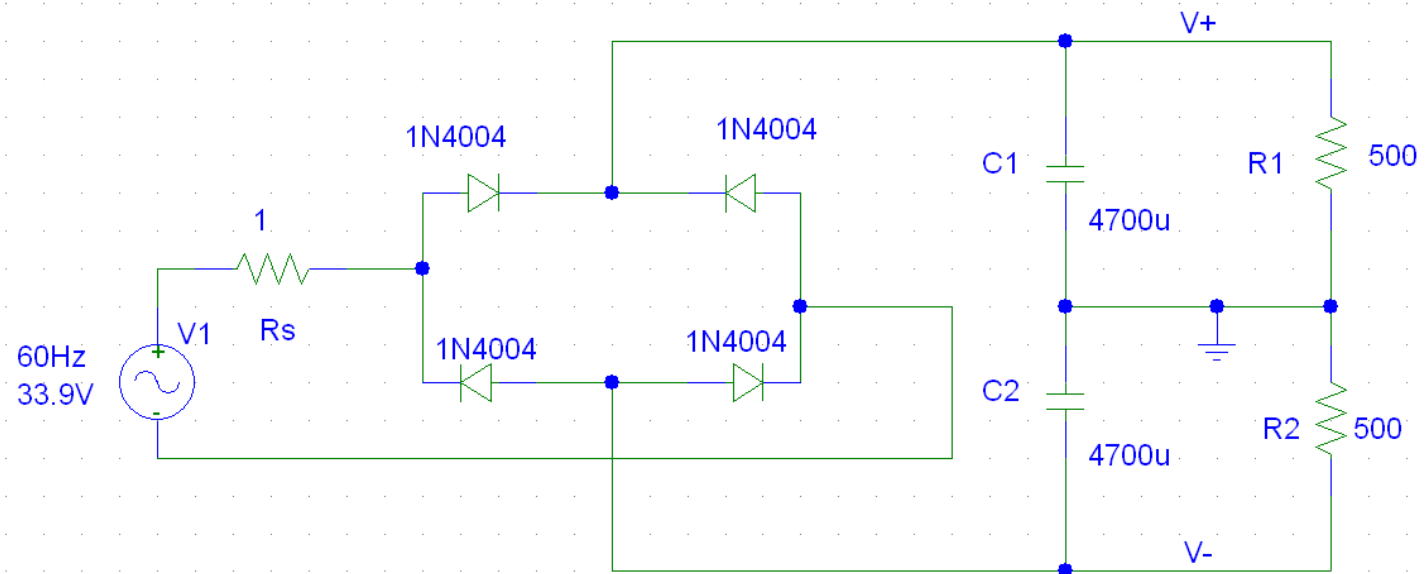

Figure 2: Full-Wave AC-DC Voltage rectifier with ripple filter.

This circuit is a full-wave AC-DC rectifier with capacitors acting to smooth the output. Resistors R1 and R2 are models of a load. Each load is one channel of the rectifier. Varying their resistance will provide different currents through the loads, (i.e. R1 and R2).

Section One: Lab Equipment (Using Your Tools)

Using the circuit in Figure 2, measure/ analyze the following:

1. Measure the output voltage (V_+ to ground and V_- to ground) for load resistance of 100, 500, 10K and 100K Ω . (The output will not be exactly DC, but will have some imperfection, which is the ripple.)
2. Report the ripple amplitude and frequency under the different load conditions. (Note that resistor R_s represents an output resistance of the source of 1 Ω . The SIN stimulus simulates a 24VAC_{rms} source).
3. Vary the size of the filter capacitors C1 and C2. What is the effect on the ripple?
4. Perform a transient analysis on the output, using the following guidelines:

SIN *<offset> <ampl> <freq>* AC transient sinusoidal stimulus.

.TRAN *<time_step> <time_stop>* Transient analysis specifier.

.PRINT TRAN *output_variables* Allows the results from the transient analysis to be an output in the form of tables, and referred to as print tables in the output file.



In PSPICE AC stimulus, the **amplitude** is specified, **not the RMS** value. Be very careful when referring to AC values. It is best to just always specify whether you are referring to RMS, amplitude (0-peak), or peak-to-peak voltages. Use this convention: VAC_{rms} , VAC_{0-peak} , VAC_{p-p} .

Also note that for sinusoidal waveforms, $V_{rms} \times \sqrt{2} = V_{0-p}$. Therefore the wall outlet is: 120 VAC, 169.7 VAC_{0-peak}, or 339.4 VAC_{p-p}. All forms are equivalent.

5. Note that you are performing a transient analysis. It takes some finite time for the output to stabilize. Which circuit components cause this? A common mistake is to run the transient analysis for too long or not long enough.



If you need help with PSPICE commands, refer to the PSPICE documentation on the CDROM (in the back of your textbook). It is located at <D:\Orcad\document\PSpcRef.pdf>, as well as on the [TekBots Web-page](#) for this course. Use the web to search for examples as well.



In engineering problems, it is often useful to consider limiting situations. For example, what happens to the output as C1 and C2 are very large, i.e. infinite? PSPICE cannot simulate infinite, instead use 1 Farad, (which is very large for a capacitor).

Similarly, what happens to the output, as R1 and R2 become very large, (i.e. no load attached)? This can be simulated by making R1 and R2 very large, i.e. 1M Ω . Be careful, however, to allow sufficient time for the circuit to stabilize. Also, be mindful of the RC time constant.

Measure/ analyze using Figure 2 (Contd.)

6. Use simulation results to determine the voltage across both load resistors, (from V- to V+).
7. Determine the minimum and maximum voltage, (keeping in mind that there should be a ripple in the voltage). Also, determine the frequency.

Note: You will need to use an AC voltage source (using the SIN stimulus) as well as the “.TRAN *time_step time_stop*” command, in order to have your simulation run for several milliseconds.

You may also want to use “.PRINT TRAN *output_variables*” to get a printing of the output voltage.

8. Repeat these simulations for a load resistor of 100, 10K, and 100K Ω .

STUDY QUESTIONS/ TURN-IN

The post-lab/ report for each week will vary slightly; so please pay attention to what the questions are, prior to starting your lab. The post-labs will consist of either questions to be answered separately, or having you update your project specification document to match your results. Sometimes, it will be a combination of the two.

The following need to be turned in, **at the beginning of the next lab session (Section Two)**:

1. An Excel graph of the oscilloscope measurements in AC and DC coupling modes from Part 4. Show the amplitude and frequency of the AC component.
2. A copy of your simulation results from Part Six. Include measurements of the ripple voltage and frequency with each load current. Comment your PSPICE net list as much as possible.
3. Lastly, turn in your **answers to the study questions** below. Please write your answers to the following set of study questions on a different sheet of paper. You may type your answers, or write them neatly by hand. Keep your answers clear and concise.

Section One: Lab Equipment (Using Your Tools)

- How is voltage ripple affected by load current (size of load resistors) and filter capacitors? What is the frequency of the voltage ripple and how is it related to the stimulus?
- How significant is the output resistance of the source? For what load currents is it non-negligible, (>5% change in output)?

✓ TA Signature: _____
(Lab work readable/ turned-in).

CHALLENGE

There will be several challenges throughout this course. Full credit for each challenge question will require a neatly drawn (or printed) schematic, along with a detailed report on your solution to the challenge problem.

- Simulate the circuit in Figure 3 using PSPICE and the models that you have downloaded. Run the simulation with various values for R4. (**Hint:** You will need to use a sub-circuit). What is the maximum current through R4 before the circuit fails to operate properly? Once you have a feel for the output of the circuit, describe in detail how the circuit operates to create this output.

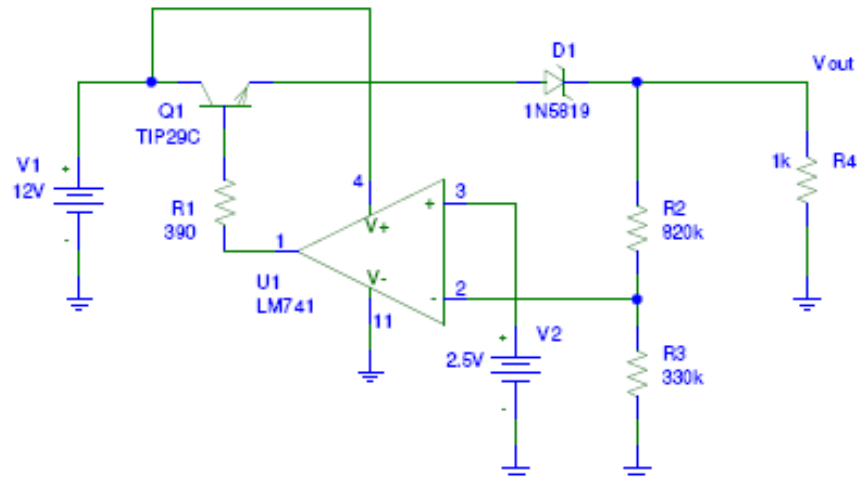

Figure 3: Challenge problem circuit

SECTION TWO

Rectifier and Filter Design

SECTION OVERVIEW

This section deals with rectifier and filter design. Following are the objectives, materials and design constraints for this lab.

Objectives

- Become familiar with the device characteristics of diodes.
- Understand the design trade-offs between half and full-wave rectifiers.
- Design and build your own rectifier and filter for your power supply that meets the design constraints.

Materials

- Oscilloscope probe, BNC to alligator clips cable, and test leads.
- Solder-less breadboard and jumpers.
- Your lab parts kit.
- MatLab or similar graphing program.
- Your textbook, *Sedra and Smith*, for reference: *5th Ed.* Pages 174-182 or *6th Ed.* 195-204.

Design constraints

Box 2 lists some of the design constraints for your final power supply that will apply to the AC-to-DC rectifier block. Be sure that you know all of the constraints and requirements to avoid confusion. These are always listed in the *Project Specification Document*. Keep these in mind as you complete this lab. Each criterion must be met.

- Two channels, one positive and the other negative when referenced ground.
- Each channel must be capable of supplying at least 900mA per channel continuously at voltages between ± 2 and ± 12 V.
- Current limiting circuitry for each channel, protecting above 1 A +/- 10%.
- Voltage ripple less than $0.75V_{p-p}$ per channel, with both channels fully loaded to 900mA.
- Easily accessible AC power switch.
- A clearly visible power indication light.
- Power supply assembled safely and with no electrical hazards and utilizes a safety fuse.

Box 2: Final power supply design constraints



This section makes several references to various AC voltages. In this section, the AC voltages are RMS values. However, you should be aware that AC voltages are sometimes given in peak-to-peak values.

PRE-LAB

This lab and every lab after it, will require a pre-lab assignment to be completed, prior to your scheduled lab time. You will be required to show the work you did, and sometimes it will be turned in for a grade. This work is an important part of each lab and will be graded. Not having any part of your pre-lab done at the beginning of lab will result in a loss of all pre-lab points.

1. Read pages 195-204 (or 172-184 in 5th edition) in your text. Understand how a half-wave and full-wave rectifier works. Understand how a capacitor is used smooth the rectified AC. Become familiar with Figure 4.20 (Figure 3.24 in 5th edition) of your text book. In this section, you will be designing and building the blocks labeled “Power transformer”, “Diode rectifier”, and “Filter”.



Bring a copy of the 1N4004 diode datasheet.

2. Derive or find the equation for voltage ripple (in your text) in half-wave and full-wave voltage rectifiers. In MatLab, or a similar program, plot the theoretical voltage ripple amplitude vs. the filter capacitor size (i.e. log plot 1nF to 1F), for a half and full-wave rectifier with:
 - Load Current: 1 A.
 - Source Frequency: 60 Hz
 - Source Amplitude: 24 VAC

LAB

This lab is divided into six parts: **diode device characteristics, half and full wave rectifier design, rectifier and filter for your power supply, transformer/ wall outlet output resistance, power indicator LED, and connector hardware.**

Part One – Diode device characteristics

An ideal diode acts as a short to current flowing in the forward direction, and acts like an open circuit to current flowing in the reverse direction. A real diode has finite resistance. A diode’s resistance is non-linear. A common characterization of diodes is a graph to relate the current flowing through a diode as a function of the voltage across it. This is referred to as an “I-V” curve. The slope of this line is admittance, or 1/resistance. A resistor’s I-V curve is a straight line.

In Part One, you will learn to: **measure the I-V characteristics of a 1N4004 diode**, as well as to **measure r_d of your 1N4004 diode.**

Measure the I-V characteristics of the 1N4004 diode

In order to measure the I-V characteristics, follow these steps:

1. Build a circuit, as shown below in Figure 4, which consists of a 1N4004 diode and a resistor to control the current. (It might be easiest to use half of a potentiometer).

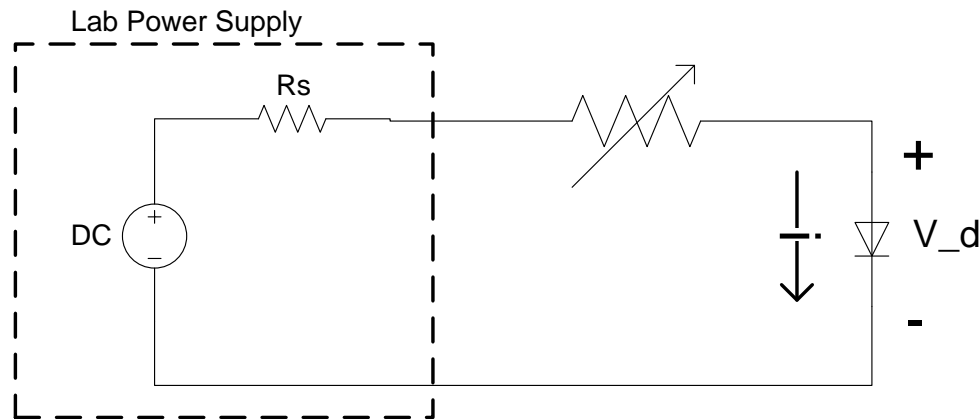

Figure 4: Diode Testing Schematic

2. Set your lab power supply to 3V and attach it to the circuit.
3. Measure the voltage drop across the diode and the current flowing through it. Take at least 10 sets of data from 0 – 100 mA. Open up Excel or MatLab at your workstation and record the data directly while you work. Take enough data to accurately reproduce the non-linear I-V characteristics.
4. Plot your data.
5. Now, answer the following:
 - a. Do your measured values look like what you expected?
 - b. Is it accurate to use 0.7V as an approximation of forward voltage drop for your diode?
 - c. If not, what range of currents would this approximation be useful for?
 - d. What is the forward voltage drop reported on the datasheet?

Measure r_d of the 1N4004 diode

Notice that r_d is the small signal resistance of the diode. Typically the voltage across a diode is a large DC bias plus a small variation from this bias. When working with small signals, it is convenient to use a linear approximation of the I-V characteristics of a diode, thereby approximating the response of the diode to small signals as purely resistive. For this approximation to hold, the small signal must be much less than the DC bias, (i.e. typically <10% of the DC bias).

In Figure 5, the bias or Q-point is the intersection of V_{dQ} and I_{dQ} . The linear approximation (solid line) applies for small signals superimposed upon the DC bias.

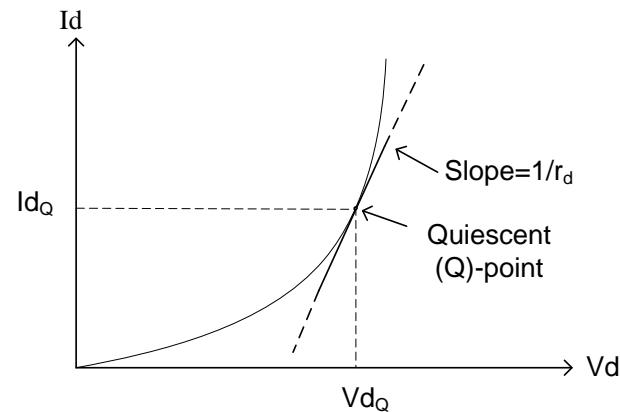

Figure 5: Q-point and r_d

In order to measure r_d of the diode, follow these steps:

1. Bias your diode with currents of 1mA, 10mA, 100mA, and 500mA DC.
2. Make a small change, (in either direction) in the bias current, and record the corresponding change in diode voltage.
3. Use these current and voltage data sets to estimate r_d for each bias current.

The definition is:

$$r_D(I_{DC}) \equiv \lim_{\Delta I \rightarrow 0} \frac{\Delta V}{\Delta I} = \frac{dV(I_{DC})}{dI}$$

4. Does small signal resistance r_d increase or decrease, as bias (DC) current is increased?

Part Two – Half and full-wave rectifier design

The process of converting AC to DC is called rectifying. There are two basic types of rectifiers: the half-wave and the full-wave. In this section, you will be designing and building both.

The output of a rectifier is typically filtered to make the output as smooth as reasonably possible. However, despite filtering, the output varies significantly under higher currents: hence, a voltage regulator is normally used in addition, when a stable voltage supply is required.

Design and build a full-wave rectifier

In order to implement the above, follow these steps:

1. Design and build a full wave rectifier that will convert 60Hz 10VAC_{0-p} to DC, to support a load that draws 1mA. Design the rectifier to have less than 1V_{p-p} ripple voltage. If you are having trouble, you may want to modify your simulation in Section One for these specifications and verify your design.
2. Generate the AC using the signal generator and use resistors to create a 1mA load.
3. Measure the DC output using the DC coupling mode of the oscilloscope.
4. Measure and record the ripple voltage and frequency using the oscilloscope.
5. Now, answer the following:
 - a. Are you able to measure peak voltage in both DC and AC coupling mode?
 - b. Is it easier to measure the ripple voltage in DC or AC coupling mode?
 - c. Your ability to make ripple voltage match your design calculations is limited by the tolerance of the capacitor, (which is often as high as $\pm 20\%$). Were you within 20% of what you calculated for ripple voltage?

Design and build a half-wave bridge rectifier

In order to implement the above, follow these steps:

1. Convert your full wave rectifier design to a half wave bridge rectifier. Use the same capacitor as you did in the full wave rectifier.
2. Use the signal generator to create the AC, and a variable resistor to create a 1mA load.
3. Measure and record the peak DC voltage and peak ripple voltage.
4. Now, answer the following:
 - a. Based on your measurements, which rectifier would you choose to use to support the load?
 - b. What design trade-offs does your chosen rectifier type have, compared to the other type? (Think about comparisons of price, reliability, time to build, quality of the DC, and why you might use each type of rectifier).
 - c. Which parts are the most expensive and how does this contribute to your choice of rectifier type? (Part numbers are included in *Appendix C: Parts*).

Part Three – Rectifier and filter for your power supply

Your power supply will need to convert 60Hz 120VAC_{rms} down to a usable 2-12V DC. The first step is to step down or reduce the AC voltage to 24VAC_{rms} using a transformer.



You may want to refer to your *Electrical Fundamentals II (ENGR 202)* notes for information regarding transformer. Specifically, you will want to be familiarizing yourself with transformer turns ratios and center-tap transformer.

You should now be able to analyze and answer the following questions:

1. If the secondary windings can pass up to 1A of current, what is the maximum primary side current that can be supplied?
2. You will be using the center tap on the secondary side as your power supply ground. What voltage will be present on the other two leads of the secondary side, (which is referenced to your power supply's ground).
3. The transformer included in your kit can support both 115VAC and 230VAC on the primary side. For 115VAC supply, you use the primary side center tap (yellow) and one of the end wires (black). What would your turns ratio and output voltage be, if you accidentally connected 115VAC across the outer two leads, and did not use the center tap on the primary side?

Section Two: Rectifier and filter design

Part Three has been divided into the following sub-sections: **design, lead usage of the transformer, electrical safety, and assembly of the power supply.**

Design

Now that you have constructed a few examples of rectifiers, you will need to implement the design that you created in your pre-lab, by observing the following:

- Select an appropriate value for the filter capacitor.
- Be sure that your rectifier meets the specifications for the sub-block, so that your power supply will be a success.
- Remember that the input voltage was about 24VAC, as per your assumptions in the pre-lab.
- You will use the included transformer in your kit to convert the 120 VAC of the wall outlet down to this 24VAC.
- You can use the schematic (in the next sub-section: Figure 6), to help you in using the transformer.

Lead usage of the transformer

Figure 6 is a schematic that illustrates the usage of the transformer.

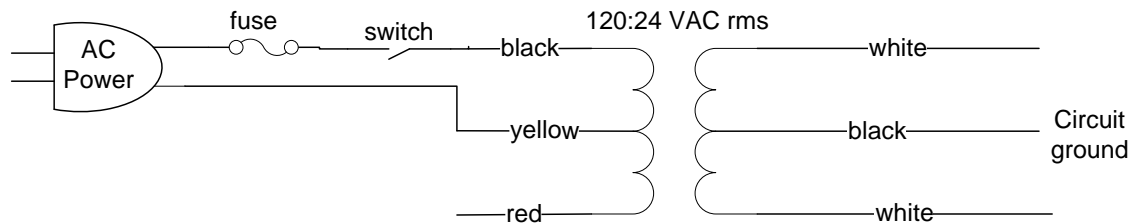

Figure 6: Schematic of transformer usage

The primary side center-tap will not be utilized. However it is still energized and must be safely terminated. Figure 7 illustrates proper termination using heat shrink wrap.

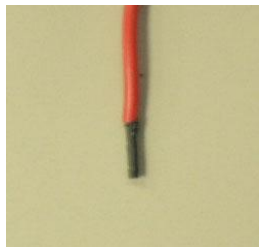

Figure 7: Safely terminated wire

Electrical Safety

In this section, you will be building circuits that will be energized by high voltage AC. Implement the safety instructions in the following caution-table before moving further:



1. Ensure that all leads and connections are secure, and that they are covered with heat shrink to insulate them.
2. You must also solder the fuse holder to the black lead of the power cord.
3. **Do not** energize this circuit, until your TA has approved the safe assembly of your circuit.
4. **Do not** forget to follow the “one hand” rule that was covered in Section One.

Refer to Figure 8 for an example of how to safely make connections for your high voltage leads. The power switch and fuse have been installed on the primary side of the transformer.



Figure 8: Safely made connections for high voltage

Assembly of the power supply

Before you place any components, you should have a good idea as to where you want to place all of the components. See Figure for an example of how you might arrange the components. Place your components inside the empty case to get an idea of where you want to place everything.

To help you along, this manual will give you suggestions about where to place your various components on the prototyping boards. You do not need to exactly follow these suggestions, but be aware that you will need to fit quite a few things into your supply case.

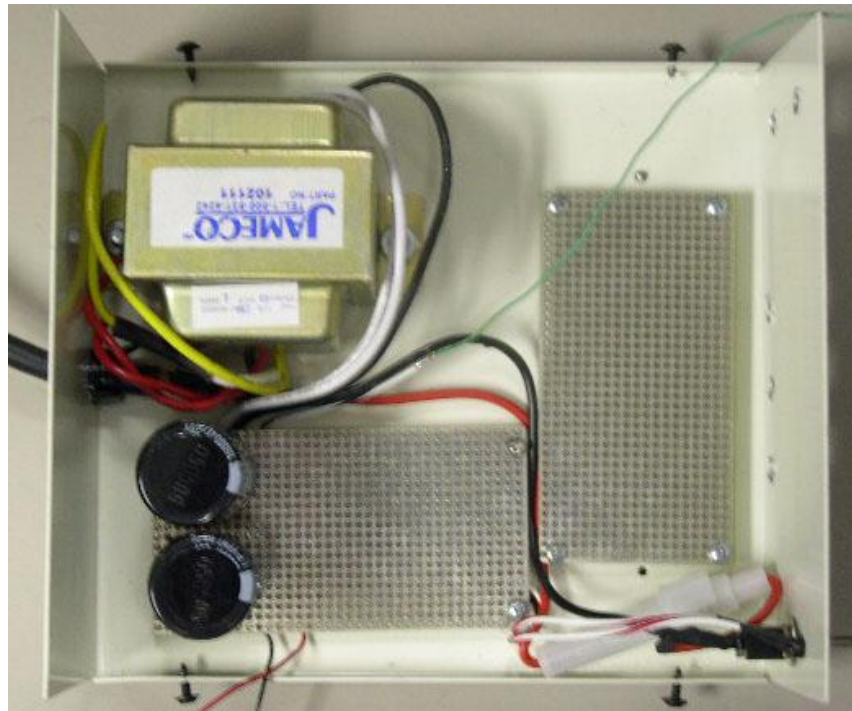

Figure 9: Example layout of the power supply components

Build your rectifier and filter circuit on one of the circuit boards in your lab kit.

You will want to make sure the transformer wires are soldered securely.



Be careful that no part of the circuit protrudes so far that it may come in contact with the aluminum base or one of the screws.

Part Four - Transformer/ wall outlet output resistance

Your transformer incurs losses at high currents. How do you know this? (**Hint:** Power losses often produce waste heat). This implies that the transformer has finite output resistance. The wall outlet also has finite output resistance.

In this section, you will need to do the following:

- Make an estimation of the output resistance of the transformer.
- Make an estimation of the output resistance of the wall power outlet.

Part Five - Power indicator LED

This is a good time to include your power indicator LED. In order to do this, follow these steps:

1. Size your resistor, such that the maximum forward current of the LED is not exceeded, but is still sufficient to light the LED.
2. Remember that the voltage can get as high as 18 VDC when the power supply is not loaded.
3. Refer to the LED data sheet to get this information.
4. You will want to pay attention to which supply you use, (either the negative or the positive supply), as it will affect the direction in which to insert the LED.

Part Six - Connector Hardware

You may use a drill to create mounting holes for all of the components. Suggested drill sizes are shown below:

- Power cord – 5/8"
- Circuit board holes – 1/8"
- Power LED – 3/16"
- Transformer screws – 1/4"
- Power switch – 1/4"
- Binding posts – 5/16"
- Potentiometers – 5/16"

If you have never used a drill before, then ask someone to show you how. But do not let them drill all your holes for you and take away the satisfaction of a job well done.

Have fun assembling your power supply. Go slowly when necessary and feel free to ask questions of your group partner when you don't understand part of this section. Other groups are also a good source of help, but do not share specific component values. Your TA is always able to help you, if needed.



The filter capacitors will remain charged even after the unit is unplugged. It will take a 2K Ω resistor about ninety seconds to discharge the capacitors.

STUDY QUESTIONS/ TURN-IN

In addition to study questions and documents to turn-in, this section introduces you to the project specifications that will be included henceforth as part of your ‘turn-in documents’.

Project Specification:

As mentioned before, you are building a power supply that meets a project specification document. For many of the following labs, you will be reminded to update the project specification with your schematics and information. Since this is the first time you have done this, go to the Web-page and download a copy of the *Project Specification Document*.

In Section 6 of the document, there are places to enter information about the various schematics for each sub-block. You will need to complete this section and update other portions of the specification. From the next lab time, you will need to turn in a copy of the sections that you have updated in the preceding week. To help you this one time alone, you get a heads-up on which sections you need to update for this lab.

The following sections of the *Project Specification Document* need to be updated:

- Section 6.2 – AC Rectifier Block
- Section 8 – Parts List and Costs Analysis
- Section 1 – Revision History

TURN-IN

The following need to be turned in, **at the beginning of the next lab (Section Three).**

Student Name: _____

Lab Section Time: _____

<u>Test (from Project Specification)</u>	<u>Measurements</u>	<u>TA Signature</u>
<u>7.1.1 - AC RECTIFIER - TWO CHANNELS, ONE POSITIVE AND THE OTHER NEGATIVE WHEN REFERENCED TO GROUND</u>		✓ _____
<u>7.1.2 - AC RECTIFIER - RECTIFY 60Hz, 120 VAC_{RMS} TO DC</u>		✓ _____
<u>7.1.3 - AC RECTIFIER - CAPABLE OF SUPPLYING AT LEAST 900mA AMP PER CHANNEL CONTINUOUSLY</u>		✓ _____
<u>7.1.4 - AC RECTIFIER - VOLTAGE RIPPLE OUT OF THE FILTER IS LESS THAN 0.75V_{P-P} PER CHANNEL WITH BOTH CHANNELS FULLY LOADED TO 900mA</u>		✓ _____
<u>7.1.5 - AC RECTIFIER - EASILY ACCESSIBLE AC POWER SWITCH</u>		✓ _____
<u>7.1.6 - AC RECTIFIER - A CLEARLY VISIBLE POWER INDICATION LIGHT</u>		✓ _____
<u>7.1.7 - AC RECTIFIER - ASSEMBLED SAFELY AND WITH NO ELECTRICAL HAZARDS AND UTILIZES A SAFETY FUSE</u>		✓ _____

The **written project specification** to be turned in next week includes:

- Project Specification Sections for this lab's circuits:
 - Block Diagram

Section Two: Rectifier and filter design

- Interface Definition
- Schematic and theory of operations
- Parts List Changes and Testing Results

The **prelab** to be completed (before lab begins next week), includes:

- Prelab for Section Three.

Lastly, turn in your **answers to the study questions** below.

Study Questions:

Please write your answers to the following set of study questions on a different sheet of paper. You may type your answers, or write them neatly by hand. Keep your answers clear and concise.

- a. At what voltage does current begin to flow through your diode in Part One of this section?
- b. If you designed a circuit that used the forward voltage drop of your diode as a voltage reference, what voltage would be provided with a forward current of 10mA?
- c. The values that you measured for peak and ripple voltage were different between the half and full wave rectifier from Part Two. What was the difference in the peak voltages? What causes this difference?
- d. What was the difference in the ripple voltages? What causes this change?
- e. How do your ripple measurements of your full bridge design of Part Three compare with the PSPICE simulation? What can explain the differences?
- f. Comment on the significance of the output resistance of the transformer and wall outlet on the output voltage in your PSPICE simulation under high load currents (1A).

CHALLENGE

The I-V curve of a diode is not always the same. Recall that in *Electronic Materials and Devices (ECE 317)*, you learned that the current through a diode depends on device characteristics that vary with temperature.

Bearing that in mind, analyze and answer the following questions:

1. Describe the effect temperature has on a diode at the atomic level.
2. Plot additional I-V curves for your diode with significant changes to temperature. You could use 32°F (0 °C) and 212°F (100 °C), as these are easy to maintain accurately during testing. Use as many temperatures as needed to accurately predict the shift in the I-V curve. Ensure the current is not so high that it causes the diode to heat up on its own.
3. Explain how the shift in the I-V is explained by your answers to Question #1.
4. Using plots of the I-V curves, create a method to easily measure temperature with a diode.
5. Use the .TEMP function in PSPICE to simulate elevated temperatures. Plot the I-V simulation result under various temperatures.

To get extra credit for the challenge problem submission, you will need to turn-in the following:

- A typed report containing your answers to the above questions.
- Any additional I-V plots that you created.
- An explanation of how a different diode, or even a transistor, might be more suitable than the diode that you chose for your design.

SECTION THREE

Voltage Regulators (Design and Building)

SECTION OVERVIEW

This section is a (three-week long) design and building project to create variable voltage regulators for your power supply. Instead of using pre-built integrated circuits (ICs), the voltage regulator will be built from discrete components. The power supply will provide both positive and negative voltage (relative to ground), and therefore requires that both a positive and negative voltage regulator be designed and built. Recall that in Section Two, you used the center tap on the secondary side of your transformer as the common node, or ground.



From now on, the term “power supply” will refer to your own power supply that you have designed and built. You will not be using the lab’s power supplies.

Objectives

- Be able to use a curve-tracer, to determine the characteristics of a transistor.
- Understand the relationships between V_{be} , V_{ce} , and I_C .
- Understand the operation of a simple two-transistor voltage regulator.
- Identify when a Darlington Pair should be used.
- Be able to design and build a positive voltage regulator from discrete components.
- Be able to design and build a negative voltage regulator from discrete components.
- Add over-current protection to your power supply.

Materials

- Oscilloscope probe and test leads.
- Solder-less breadboard and jumpers.
- Your lab parts kit.
- Semiconductor datasheets (TIP29C, 2N4401).
- BJT characteristic equation summary

Design Constraints

Box 3 lists the design constraints for your voltage regulators. Keep these in mind as you complete each section of this lab. You must meet each criterion.

- Two channels, one positive and the other negative when referenced to ground.
- Each channel must be capable of supplying at least 900mA per channel continuously at voltages between ± 2 and ± 12 V.
- An overload to limit current to 1 amp (+/- 10%).
- External connections for leads and voltage adjustment.
- Power supply assembled safely and with no electrical hazards.

Box 3: Voltage regulator design constraints

PRE-LAB

The lab portion of Section Three has **eight parts that must be completed in four weeks. You may work ahead if you like, but do not fall behind. In order to understand the pre-lab questions, you must read the lab for that week first.**

The Pre-lab for each Lab Part has been outlined below:

Week 1	Complete Pre-lab for Parts 1, 2, 3 and 4
Week 2	Complete Pre-lab for Parts 5, 6, and 7
Week 3	Complete Pre-lab for Part 8
Week 4	Finish up

Be sure to organize the *pre-labs* according to their respective *parts* in this lab-section. Leave a page or two between the pre-lab for each part, so that you can add notes and comments. As an example, see “sample” lab notebook page at the end of this section.



You will need to refer to the data sheets for the 2N4401 NPN transistor and the TIP29C transistor, for the Pre-Lab of this section (Section Three).

Pre-lab for Part One

For the pre-lab in this part, implement the following:

1. Read the *Electrical Characteristics* section of the data sheet for the 2N4401 NPN transistor. Pay close attention to the information on $V_{be}(\text{sat})$, $V_{ce}(\text{sat})$, and β . Notice that β is typically called “ h_{FE} ” on data sheets.
2. Locate the *Absolute Maximum Ratings* section (including the thermal characteristics, if they appear separately) and record the values found there.
3. Look over the graphs on the data sheet that show how I_c relates to V_{ce} , V_{be} , and β .
4. Repeat #1 for the TIP29C NPN power transistor.
5. Explain the circumstances under which you would choose to use the 2N4401, and when you would choose to use the TIP29C transistor.
6. Bring in a printed copy of the datasheets used for the above comparisons. You should have datasheets for the TIP29C and 2N4401.

Pre-lab for Part Two

Analyze the circuit used in this section, with and without emitter resistance. This includes the mode of operation, operating current (I_c), base current, and gain.

Pre-lab for Part Three

For the pre-lab in this part, implement the following:

1. Write out an explanation for the operation of the voltage regulator circuit in Figure 11.
2. For the given R_1 and R_2 values, what would you expect the output voltage to be? Explain.
3. What will be the operating mode of Q_1 and Q_2 ? (Assume that V_{in} is from your rectifier circuit).

Pre-lab for Part Four

1. How would you modify the circuit implemented in Part Three, so that the output voltage can be changed by turning a potentiometer, (used as a variable resistor)? Sketch a schematic of the circuit you propose to implement.
2. Write out an explanation in your notebook as to why or how your modification makes the output voltage adjustable.
3. Include a table that provides a cost analysis for your modification.

Pre-lab for Part Five

1. Review section 7.6.3 (5th Ed.: 14.7.2) of your textbook for the operation and advantages of a Darlington pair configuration. Sketch a schematic of the voltage regulator circuit, which has been modified with a Darlington pair in place of Q1 in Figure 11.
2. Why would you consider implementing the Darlington pair with a TIP29C and a 2N4401, (instead of two TIP29C transistors or 2N4401 transistors)?
3. Calculate the current gain of a Darlington pair consisting of a TIP29C and a 2N4401 using the data sheets.
4. Update your cost analysis.

Pre-lab for Part Six

1. How would you modify the voltage regulator circuit implemented in Part Five, in order to ensure it operates within the specified voltage range? Sketch a schematic of the circuit you propose to implement.
2. Write out an explanation as to why or how your modification ensures Q2 is not accidentally damaged.
3. Update your cost analysis.
4. Bring a copy of your 'final' positive voltage regulator circuit, and show it to your TA.

Pre-lab for Part Seven

1. Design a negative voltage regulator similar to the positive voltage regulator. Sketch a schematic of the circuit you propose to implement.
2. Compare the datasheets for the transistors used in the negative regulator to those used in the positive regulator. How do they differ? How will this impact the performance of the regulator?
3. Update your cost analysis.

Pre-lab for Part Eight

1. Explain how shorting the output would damage the circuit. Which absolute maximums are being violated?
2. Design an addition to your voltage regulator that will limit the output current to 1A. Sketch a schematic of the circuit that you propose to implement.
3. Write out an explanation in your notebook as to how your limiting circuit works.
4. Update your cost analysis.

LAB

The lab for this section has the following eight parts: **transistor device characteristics, relationships between V_{be} , V_{ce} and I_c , two-transistor voltage regulator, variable voltage supply, Darlington pair usage, positive adjustable voltage regulator, negative voltage regulator, and over-current protection.** Finally, the circuit design is tested after Part Eight is completed. You may work ahead if you like, but do not fall behind.

Part One – Transistor Device Characteristics

Your TA will demonstrate how to use the curve-tracer to measure the $I_c - V_{be}$ and $I_c - V_{ce}$ curves (for several V_{be} values).



Pay close attention to what your TA's demo, since you will be taking the same measurements with your own transistor.

As it becomes available, use the curve tracer to take I-V curves of one of your 2N4401 transistors. From these plots determine and record V_A , r_o , V_{be} (sat), V_{ce} , g_m , β , and r_π . Where possible, compare these values to the data sheet. Note any differences from the values that you measured.

Part Two – Relationships between V_{be} , V_{ce} and I_c

In this part, you will **use the following**:

- Potentiometers as variable resistors to vary V_{be} and V_{ce} . Note the change in I_c and in the gain that this causes.
- Unregulated voltage from your power supply to power the circuit.
- A fan, as your load.

Now, **build a test circuit**, as follows:

1. Insert a 2N4401 transistor into your breadboard.
2. Place a potentiometer on the transistor base, so that it forms a voltage divider between V^+ and ground of your rectifier output.

Note: This will use all three leads of the potentiometer.

3. Adjust the potentiometer so that the output of the voltage divider is 0V.

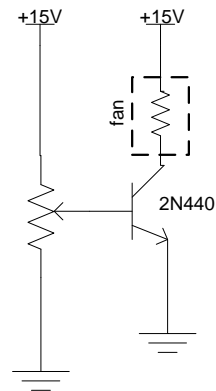

Figure 10: Test circuit

Build a test circuit (Contd.)

4. Attach the fan between V^+ of your rectifier and the transistor collector.
5. Use a potentiometer as a variable resistor between the transistor emitter and ground.



Make sure this potentiometer is set to zero ohms or as close to it as possible.

6. Turn on the power supply to energize the circuit. If you have built it correctly, the V_{be} is less than $V_{be(on)}$ and the fan will not be turning ($I_c = 0$ Amps). Equivalently, insufficient base current is flowing into the base to allow non-negligible collector current to flow.
7. Slowly raise the base voltage until the fan just begins to turn. Record the V_{be} , V_{ce} , and I_c at this point. What is the gain? What is the voltage drop across the fan?
 $V_{be} \blacktriangleright$ _____; $V_{ce} \blacktriangleright$ _____; $I_c \blacktriangleright$ _____.
8. Continue raising the base voltage until the voltage drop across the fan is 12V. Record gain, V_{be} , V_{ce} , and I_c , and the voltage drop across the fan.
 $V_{be} \blacktriangleright$ _____; $V_{ce} \blacktriangleright$ _____; $I_c \blacktriangleright$ _____.
9. Slowly add resistance to the emitter of the transistor by adjusting another half-potentiometer. What effect does this have on the values that you just measured? What is the relationship between emitter resistance and the voltage drop across the fan (your load)? What effect does it have on I_c ? Emitter resistance provides negative feedback, thus bringing stability to the circuit.

Part Three – Two-Transistor Voltage Regulator

A power supply is not very useful if we cannot control the output voltage. In Part Two, you probably noticed that the voltage out of the rectifier changed slightly when you applied a load. This is a typical response of a transformer to increased load. It can be especially annoying if you have to measure V^+ every time you make a change to the loading on the system. It would also be nice to remove the voltage ripple, so that you can provide clean power to sensitive circuits.

In this part, you will build a very simple two-transistor voltage regulator that uses negative feedback to control output voltage. **Negative feedback** is a type of feedback, where the system responds in an opposite direction to the perturbation. In this case, if the output voltage begins to rise, the system acts to decrease it, and vice versa. Feedback consists of a “sampling” of the output, which in turn is fed back to an earlier part of the circuit. You are not expected to know how to design this circuit: so, a schematic will be provided, which is Figure11 on the next page. Use 2N4401 transistors for Q1 and Q2.

Section Three: Voltage regulators (Design and building)

Build the voltage regulator, as shown in Figure 11, on your solder-less breadboard. Measure output voltage with no load and with a 1mA, 10mA, 100mA, and 200mA load. Circuit characteristics can change over time: so, hold each current for one minute and measure the voltage again, before you proceed to the next current setting.

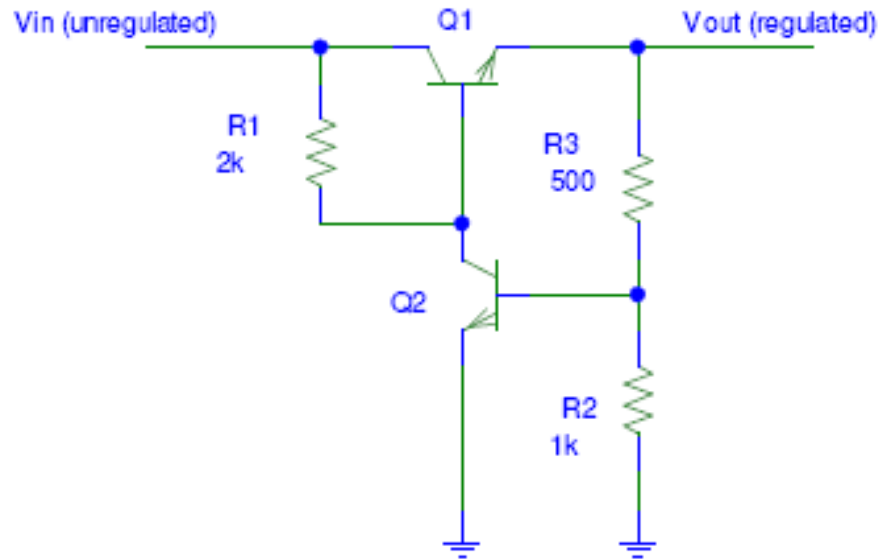

Figure 11: A two-transistor voltage regulator

Now, analyze and answer the following:

- Did you notice any problems with $Q1$ while measuring output voltage at each current?
- None of the loads you applied exceeded the 600mA rating of the 2N4401 transistor: then, why did $Q1$ fail to work correctly?
- Calculate the power being dissipated in $Q1$ and compare it with the maximum power dissipation of the 2N4401. Was this maximum limit exceeded?
- Based on the maximum power dissipation, calculate the largest current that your circuit can provide. Does the circuit satisfy all of the design requirements?

Now that you have had a chance to become familiar with the operation of the circuit, it is time to dive into how it works.

- R1 is a pull up resistor and was used in every class from *Introduction to ECE: Concepts* (ECE 112) to *Digital Logic Design Laboratory* (ECE 272). Its purpose is to keep Q1 in saturation, unless something else can pull down on the base of Q1 harder than R1 is trying to pull it up.
- Q1 is like a water valve: as you “open” it, more current is allowed to flow. In this case, we saturate Q1 to allow current to flow, and bring it out of saturation to reduce the current flowing out of the emitter. If Q1 is fully saturated, the output voltage is nearly equal to the input voltage.
- The voltage at the node between R2 and R3 has a constant voltage. It is determined by Q2. What mode should Q2 be operated in?
- R2 and R3 form a voltage divider that has a pre-determined voltage. If voltage is constant, then adjusting the values of R2 and/ or R3 have what effect on Q2? Does the current flowing through R2 ever change? Will the current flowing through R3 ever change?
- Q2 enables the negative feedback to the system, by turning the valve (Q1) more on (and therefore saturating Q1), or more off (and therefore bringing Q1 out of saturation). R1 and R2 “sample” the output and pass this information to Q2, which in turn controls Q1.

Think about how this circuit works to maintain a constant voltage, and be able to explain it in your own words. Do not proceed if you do not understand this circuit well enough to explain its operation to a first-year student in EECS.

Part Four – Variable Voltage Supply

This voltage regulator is very limited: there is no way to change the output voltage. Modify the circuit so that the output voltage can be changed by turning a variable resistor, (that is: half of a potentiometer). Be able to explain why your design caused the output voltage to be adjustable. Record the minimum and maximum voltage attainable when using the fan as a load.

Using a 2N4401 transistor for Q1 limits your voltage regulator, (and you should have determined this already). Replace Q1 with a TIP29C transistor. Why does this transistor work better than a 2N4401 in this situation? If you are not sure of the difference, rebuild the circuit in Figure 11, (but using a TIP29C for Q1 this time).

Load the circuit to 100mA and 200mA and compare your results to what you had previously, when Q1 was a 2N4401. It may also be helpful if you look at the maximum current and the power that each transistor is capable of.

Vary the output voltage while using the fan as a load. What is the minimum and maximum attainable voltage? How does this compare to when Q1 was a 2N4401? Can you meet the design constraints of the project specification?

If TIP29C is not performing the same as the 2N4401, refer to the transistor data sheets and think about the way this circuit operates. Can you determine what changed and why?

Part Five – Darlington Pair Usage

A common way to overcome the limitations of power transistors, yet obtain the high gain, is to use a Darlington Pair. Refer to your class notes and section 7.6.3 (5th Ed.: 14.7.2) of your text book, as needed.

Modify the two-transistor voltage regulator to utilize a Darlington pair, in place of Q1. The Darlington pair will use the TIP29C and a 2N4401.

As in Part Four, vary the output voltage while using the fan as a load. What is the minimum and maximum attainable voltage?

Treating the Darlington Pair as a single transistor, measure its gain while powering the fan. Calculate the gain of the Darlington pair by using data sheet values, (that is, by using the h_{fe} values from the data sheet graphs that correspond to the I_c values you are using). Compare your measured and calculated values of gain.

Part Six – Positive Adjustable Voltage Regulator

The voltage regulator you built in Part Five is almost a complete regulator, though a few more additions need to be considered.



The potentiometer that is used to set the current into the base of Q2 can accidentally be adjusted to the extent that Q2 may get damaged by exceeding its V_{ce} limit. Modify your design to fix this.

However, make sure that modifications do not preclude you from meeting all of the design constraints.

Noisy loads like the fan require that you place an electrolytic capacitor on the voltage regulator output to ground. Since a capacitor appears like a short to high frequency signals, they pass through it to ground, rather than interfering with your regulator output. This capacitor will remove high frequency noise that some loads will generate. Pick a large electrolytic capacitor to remove the noise of the fan and other large loads that could cause noise.

This voltage regulator works a lot like the LM78L05 voltage regulator you used in *Digital Logic Design Laboratory* (ECE 272). Refer to your ECE 272 lab notes or the LM78L05 datasheet to determine what you should add to the input and output of your voltage regulator.

Carefully consider the layout of the inside of the case before you begin. You may want to build your power supply from input-to-output-blocks. An example layout of the blocks is shown in Figure 12. Build the voltage regulator on the circuit board once you are happy with your design.



You can drill a hole in the metal case, so that the potentiometer is accessible when the cover is installed.

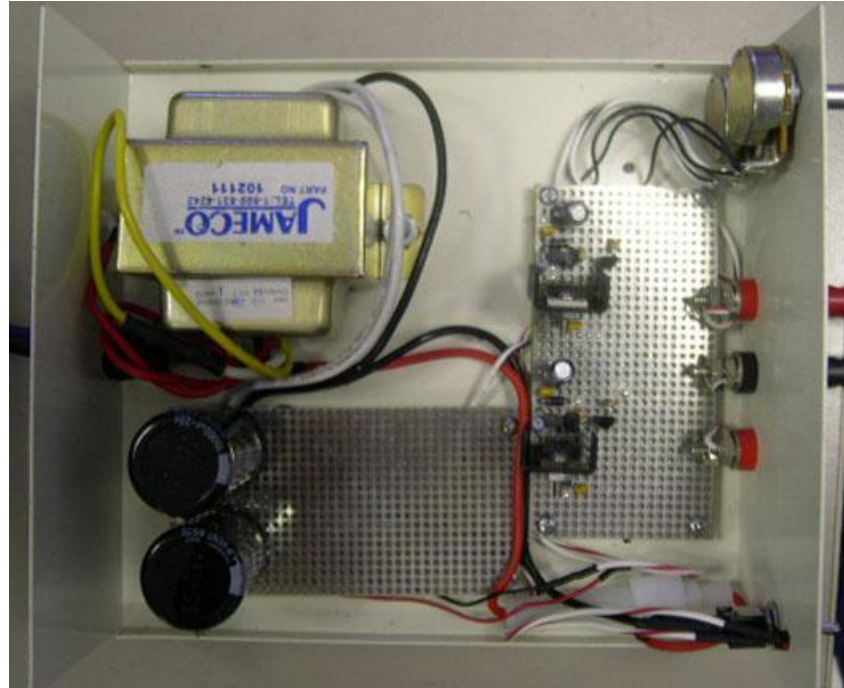

Figure 12: Example layout of voltage regulators

Part Seven – Negative Voltage Regulator

At this point of the lab, you have a working positive voltage regulator! Now, all you need to do is to design and build a negative voltage regulator.

You will have to design this regulator on your own, using the knowledge you gained from building the positive voltage regulator. It may be difficult to build the negative voltage regulator, as everything may seem backwards from the way you are used to thinking. However, you may find it helpful to start with the basics. Go back to the design for the two-transistor voltage regulator, and adapt it to allow current to flow in the opposite direction. If it helps you, draw arrows on the schematics for the positive regulator. Then, turn them around in the manner that they would be, in the negative regulator.

Once you have a two-transistor version working, expand on the design until it includes the same features and components as the positive voltage regulator. Seek help, as needed, from your group partner, other groups, or your TA.



**Be very careful when you insert polarity sensitive components.
The ground terminal is at a higher potential than your negative channel.**

Part Eight – Over-Current Protection

Hopefully, you have not accidentally shorted one or both of your voltage regulator outputs. If you did, then you probably noticed a column of smoke rising up from a blob that used to be a transistor. You need to design an addition to both of your voltage regulators to cause them to shut down if more than 1 A is drawn from either regulator, (commonly referred to as the channels).

Recall that in Part Three, the transistor Q2 maintained output voltage by pulling Q1 out of saturation. In other words, it pulled base current away from Q1, when it was providing too much current at the output. You will also need to add a transistor to pull this base current away from Q1 (i.e. pull Q1 out of saturation), when the load current is too high. Q2 uses output voltage to create a base current that gets amplified. Think of a way to sense when the current is 1 A and use this “information” to turn on your transistor, so that it will pull Q1 out of saturation.

Do not worry about being able to wire your transistor’s emitter to the common ground, as with Q2. Think of the voltage requirements of your emitter. Make sure that the collector voltage is high enough above the emitter voltage, to allow current to flow away from the base of Q1.

Do not forget to implement over-current protection for both the positive and negative voltage regulators. Show your completed design to the TA for approval. Once approved, add the components to your voltage regulators. Be careful to install them correctly, without causing any damage to any of the components.

Testing

To test the design circuit, follow these steps:

1. Power up your power supply, and touch one of the voltage regulator leads to ground.
2. Use multimeters to monitor current and output voltage, and to thus verify that the circuit is working properly.
3. If your design is adequate, the current should stabilize at around 1A, and the voltage drop will be as low as needed, in order to match this current drawn, given the impedance of your regulator circuits.



If you forgot to attach a heat sink to the TIP29C, then it is probably starting to get very hot, and could exceed a thermal limit.

Stop the test and install the heat sink if not yet installed. Then, resume the test.

4. If the regulator is robust and working as designed, running the design for thirty seconds is adequate to prove the design.



Running the design for an indefinite time could short the output.

5. Repeat the test on your other channel.
6. Demonstrate your working power supply to the TA.



- a. If your regulator stops working, then the first thing to do is to check for a loose wire.
- b. If you know a part was damaged from heat or too much current, then check your transistors to see if they got damaged.
- c. It is not unusual for one transistor to get damaged, resulting in an internal short that then damages other transistors.

STUDY QUESTIONS/ TURN- IN

Project Specification:

As mentioned before, you are building a power supply that meets a project specification document.

Update the following in the *Project Specification Document*, and submit a copy of the **updated** pages to your TA:

- Section 6.3 – Positive Voltage Regulator Block
- Section 6.4 – Negative Voltage Regulator Block
- Section 8 – Parts List and Costs Analysis
- Section 1 – Revision History

TURN-IN

The following need to be turned in, **at the beginning of the next lab (Section Four)**.

Student Name: _____

Lab Section Time: _____

<u>Test (from Project Specification)</u>	<u>Measurements</u>	<u>TA Signature</u>
<u>7.1.8 - VOLTAGE REGULATORS - ONE POSITIVE CHANNEL WHEN REFERENCED TO GROUND IS CAPABLE OF SUPPLYING AT LEAST 900mA CONTINUOUSLY (2 ~ 12V)</u>		✓ _____
<u>7.1.9 VOLTAGE REGULATORS - ONE NEGATIVE CHANNEL WHEN REFERENCED TO GROUND IS CAPABLE OF SUPPLYING AT LEAST -900mA CONTINUOUSLY (-2 ~ -12V)</u>		✓ _____
<u>7.1.10 - VOLTAGE REGULATORS - MUST SUPPLY A RANGE OF AT LEAST 2 ~ 12V UNDER ALL LOAD CONDITIONS</u>		✓ _____
<u>7.1.11 - VOLTAGE REGULATORS - POSITIVE CHANNEL HAS OVERLOAD PROTECTION TO LIMIT CURRENT TO 1A ±10%</u>		✓ _____
<u>7.1.12 - VOLTAGE REGULATORS – NEGATIVE CHANNEL HAS OVERLOAD PROTECTION TO LIMIT CURRENT TO -1A ±10%</u>		✓ _____
<u>7.1.13 - VOLTAGE REGULATORS - POWER SUPPLY ASSEMBLED SAFELY AND WITH NO ELECTRICAL HAZARDS</u>		✓ _____
<u>7.1.14 - VOLTAGE REGULATORS - BJT USAGE</u>		✓ _____

Section Three: Voltage regulators (Design and building)

The **written project specification** to be turned in next week includes:

- Project Specification Sections for this lab's circuits:
 - Block Diagram
 - Interface Definition
 - Schematic and theory of operations
 - Parts List Changes and Testing Results

The **prelab** to be completed (before lab begins next week), includes:

- Prelab for Section Four.

Lastly, turn in your **answers to the study questions** below.

1. Explain in your own words how the two-transistor voltage regulator in Part Three responds to increases and decreases in load current. Include in your explanation every affected voltage, current, and the effect this has on the transistors. Also, include an explanation of why turning the potentiometer causes the output voltage to change.
2. When you changed Q1 from a 2N4401 to a TIP29C transistor, the gain was reduced. You had to compensate by building a Darlington Pair to amplify the base current of the TIP29C. Explain what physical difference inside the TIP29C changed to support higher current, but also resulted in lowering the gain.



You may find it helpful to look at your ECE 317 notes and text, to find the equation for β .

3. Why do PNP transistors exhibit a lower gain than NPN transistors?
4. The TekBot base that you built in *Introduction to ECE: Concepts* (ECE 112) has a charger board with a voltage regulator on it. Calculate the voltage at test pad "T1" on the chrg.1 board.



You may need to refer to your op-amp notes from *Electrical Fundamentals I* (ENGR 201), to remember the basics regarding input voltages to an op-amp.

5. Assume that the TL431 is set to 2.5V. Compare the design and cost of your voltage regulator to the chrg.1 board.

Note: Do not include C3, and parts to the left of it, or parts to the right of T1, in your comparison.

Do not forget to include an actual dollars' cost for the chrg.1 board in your comparison.

Be detailed in your analysis of the chrg.1 board.

Suggest at least one change that you could make to it, to either improve the functionality, or reduce the cost (without affecting minimum performance).

CHALLENGE

1. Add an LED to each channel that will turn on when there is an over-current condition. Make sure that your design does not exceed any of the maximum limits of the LED under any operation condition.

SECTION FOUR

Operational Amplifiers: Temperature-Controlled Fan

SECTION OVERVIEW

In this section, you will resume the task of building your power supply. Use your knowledge of operational amplifiers (Op-Amps), to construct a circuit that will control the speed of a cooling fan based on temperature.

Objectives

- Design a circuit with an operational amplifier
- The op amp controls the speed of the fan, based on the temperature inside the power supply case.

Materials

- Your lab kit and power supply.
- Test leads and oscilloscope probes.

Design Constraints

Box 4 lists some of the design constraints for the fan controller. The best source for these constraints is the *Project Specification Document*. Keep these in mind as you complete each section of this lab. Each criterion must be met.

- Safely equipped with a cooling fan that should not normally be running at 70°F, but should still be able to reach rated speed around 95°F.
- Design should use an op-amp, and a BJT (or MOSFET) to control the fan speed.
- Assembled safely and with no electrical hazards.

Box 4: Fan controller design constraints

PRE-LAB

For the Pre-lab for Section Four, complete the following:

1. Using SPICE, design and simulate a circuit that will control the speed of a fan based on temperature. (You can model the fan as a resistor, but choose the resistor value carefully).



Refer to your notes from *Electrical Fundamentals I* (ENGR 201), if you have forgotten how to use an Op-Amp or your own notes from this course. For more information about the thermistor and the fan in your kits, you may want to visit the supplier Web-site and check the datasheets for the components. If this is not sufficient, perform experiments to verify the values of the components.

Hint: Double-check the current needed for the fan, and make sure your circuit can handle it.

2. Bring a printed copy of the datasheets for the parts used in this lab. These should include the datasheets for the LM/UA 741 (or some other op-amp), the thermistor, and any transistors that you may use in this lab.

LAB

There is only one part/ task for the lab portion in Section Four, which is the **fan controller**. In order to design and build a circuit that automatically varies the cooling fan speed, based on the input from a thermistor, follow these steps:

1. **Build your design** on solder-less breadboard.
2. **Test your design.** The fan should turn slowly, or not at all, when the temperature sensor is cool (about 70-75°F).



The thermistor you will be using is of type “NTC” (Negative Temperature Coefficient). This means that the resistance of the thermistor lowers as the temperature rises.

3. **About the voltage:** The voltage on the fan is about 11-12V when the sensor is warm, (i.e. at about 90 - 95°F).



Do not forget that the fan represents a load, and therefore needs to be included while designing.

4. **Verify the operation:** Verify these operating points, by comparing the fan speed at room temperature, and while the sensor is being pinched between warm fingers.
5. **Add the controller** to your power supply. Carefully consider the sensor and fan placements in order to obtain the best cooling and most accurate measurement of temperature.
6. **Demonstrate your working design** to the TA.



Power supplies can be cooled passively, (i.e. without a fan). This type of design would require you to mount the TIP29/ TIP30 transistors to the case.

Another consideration with this design is that the part of the case to which you mount your transistor, must have numerous cooling fins.

TURN-IN

The following need to be turned in, **at the beginning of the next lab (Section Five)**.

Student Name: _____

Lab Section Time: _____

<u>Test (from Project Specification)</u>	<u>Measurements</u>	<u>TA Signature</u>
<u>7.1.15 - THERMAL PROTECTION BLOCK - FUNCTIONAL COOLING FAN</u>		✓ _____
<u>7.1.16 THERMAL PROTECTION BLOCK - DESIGN SHOULD USE AN OPAMP AND A BJT OR MOSFET TO CONTROL THE FAN</u>		✓ _____
<u>7.1.17 - THERMAL PROTECTION BLOCK - THE FAN AND ITS CONTROL CIRCUIT ARE ASSEMBLED SAFELY AND WITH NO ELECTRICAL HAZARDS</u>		✓ _____

The **written project specification** to be turned in next week includes:

- Project Specification Sections for this lab's circuits:
- Block Diagram
 - Interface Definition
 - Schematic and theory of operations
 - Parts List Changes and Testing Results

The **prelab** to be completed (before lab begins next week), includes:

- Prelab for Section Five.

Lastly, turn in your **answers to the study questions** below.

1. Write a description of the type of circuit that you have built. Include a discussion of whether it has positive or negative feedback, is inverting or non-inverting, and about the gain. Explain why you chose this design and how it works.

2. Does the current flowing through your thermistor cause it to heat up? How much power are you dissipating in the thermistor? Explain why you do or do not consider this power dissipation to be a problem.

CHALLENGES

1. Modify the fan controller to have hysteresis, thereby causing the fan to continue running until the temperature has fallen below that value, (which caused the fan to turn on). For this design, your fan should actually turn off when cool, rather than just slowing down.
2. Mount your fan in a way that either increases performance, reduces noise, looks cool, or all of the above. Make sure that your fan modification is safe and does not expose any blades.

SECTION FIVE

MOSFETs: Discharging Filter Capacitors

SECTION OVERVIEW

You may have noticed that the power LED on your power supply stays on for a long time, even after you turn off the power switch. This is a result of large filter capacitors, which slowly discharge through the LED, but still retain large amounts of energy long after the power is turned off. In this section, you will be improving the safety of your power supply by designing a circuit that will discharge these capacitors to a safe voltage, within moments of the power being turned off.

Objectives

- Design a circuit to discharge the filter capacitors to a safe voltage, after the power is turned off.

Materials

- Your lab kit and power supply.
- Test leads and oscilloscope probes.

Design Constraints

Error! Reference source not found. lists some of the design constraints for the capacitor discharge circuit. The best source for these constraints is the *Project Specification Document*. Keep these in mind as you complete this lab. Each criterion must be met.

- Discharges the filter capacitor on each channel to under 3V in five seconds or less, when the main power switch is turned to off, and when there is no load present on the output of the supply.
- Design using one (or more) MOSFETs.
- Does not increase the ripple voltage of the capacitor when the power supply is turned on beyond the requirements outlined for the power supply in earlier sections.
- Safely assembled.

Box 5: Filter capacitor discharge circuit design constraints

PRE-LAB

For the pre-lab in this section, implement the following:

1. Using PSPICE, design and simulate a circuit that will discharge the filter capacitors, as per the design constraints of Box 5.
2. Use the following hints to help you with the design simulation.

- Hints:**
- (a) You may find it useful to think of this design as having two parts.
 - (b) The first part is how to use the MOSFET drain and source, in order to create a path to discharge the filter capacitors.
 - (c) The second part is to decide as to how to turn this path on and off, when the power switch is turned off (and on) respectively.
 - (d) Once you turn off your power switch, the voltage across your rectifier capacitors does not change quickly. What happens to the voltage across the secondary of your transformer once you turn off your power switch?

3. Bring a printed copy of the datasheets for the parts used in your design, to lab.

LAB

There is only one part/ task for the lab portion in Section Five, which is the **filter discharge circuit**. In order to build a circuit that quickly discharges the filter capacitors, when the power is turned off, follow these steps:

1. Build your design on solder-less bread board.



A common and simple way to discharge filter capacitors is to place a resistor across the capacitors. However, bear in mind that this increases the voltage ripple and therefore, it can still take up to a minute to discharge these large capacitors.

2. Test your design, making sure all the design constraints are met.
3. Add the circuit to your power supply.
4. Demonstrate your working design to the TA.

TURN-IN

The following need to be turned in, **at the beginning of the next lab.**

Student Name: _____

Lab Section Time: _____

<u>Test (from Project Specification)</u>	<u>Measurements</u>	<u>TA Signature</u>
<u>7.1.18 - CAPACITOR DISCHARGE BLOCK - THE FILTER CAPACITOR FOR THE POSITIVE CHANNEL DISCHARGES TO UNDER 3 VOLTS IN 5 SECONDS OR LESS WHEN THE MAIN POWER SWITCH IS TURNED TO OFF AND NO LOAD PRESENTS ON THE OUTPUT OF THE SUPPLY</u>		✓ _____
<u>7.1.19 CAPACITOR DISCHARGE BLOCK - THE FILTER CAPACITOR FOR THE NEGATIVE CHANNEL DISCHARGES TO UNDER MAGNITUDE OF -3 VOLTS IN 5 SECONDS OR LESS WHEN THE MAIN POWER SWITCH IS TURNED TO OFF AND NO LOAD PRESENTS ON THE OUTPUT OF THE SUPPLY</u>		✓ _____
<u>7.1.20 - CAPACITOR DISCHARGE BLOCK - DESIGN USED ONE (OR MORE) MOSFETS</u>		✓ _____
<u>7.1.21 - CAPACITOR DISCHARGE BLOCK - CAPACITOR RIPPLE VOLTAGE STILL MEETS SPEC OUTLINED IN EARLIER SECTIONS</u>		✓ _____

The **written project specification** to be turned in next week includes:

- Project Specification Sections for this lab's circuits:
 - Block Diagram
 - Interface Definition
 - Schematic and theory of operations
 - Parts List Changes and Testing Results

Lastly, turn in your **answers to the study questions** below.

1. The voltage of the capacitors discharges quickly at first, then more slowly after a second or two, and then finally it seems to stop discharging. Explain the following:
 - (a) Why is the discharge rate not constant?
 - (b) Why does the discharge stop, when a voltage still remains across the capacitors?
 - (c) How could you cause the voltage to continue to drop all the way to 0V?
(Hint: You should know the answer to this, using the knowledge from many earlier courses.)

2. Provide a clear description of the current and voltages of each component in your discharge circuit, when:
 - (a) The power switch is on.
 - (b) In the seconds following the switch being turned off.
 - (c) Also, justify why you are able to exceed the component limits, even if your circuit does exceed any limits at any time.

3. Calculate the time it takes for your circuit to discharge the filter capacitors to 37% of the operating voltage.

CHALLENGES

1. Your power supply does not warn you of over-current conditions. Design and build a circuit to sound a buzzer, (or light an LED), if either channel exceeds a current limit, (as defined by the power supply design constraints in earlier sections).
2. Even with a circuit to discharge the filter capacitors, your power LED may glow dimly long after the power supply is turned off. Design and implement a modification that will cause the power LED to turn off immediately after the power switch is turned off

SECTION SIX

Power Supply (Final Assembly and Testing)

SECTION OVERVIEW

This section is basically for adding the finishing touches to your design, completing the assembly, and having it tested. Modify your case to make it uniquely yours, if there is time. Other modifications to improve safety, performance, or features are encouraged.

Objectives

- Add protection from external voltage sources.
- Complete the process of building the power supply.
- Test the power supply to ensure compliance with design constraints.
- Add creative modifications to the power supply.

Materials

- Your lab kit and power supply.
- Test leads and oscilloscope probes.

Design Constraints

Refer to Box 1 (in Section One) for the design constraints that your power supply must meet.

Testing Procedure

Your TA will test your power supply, by following the System tests from the project specification (section 7.2). You may want to run some of these tests on your own, in order to ensure that you will pass them during the official test.

PRE-LAB

For the pre-lab in this section, bring the following:

1. One printed copy of your final presentation.
2. One printed copy of your finished *Project Specification Document*.

LAB

There are four parts for the lab portion in Section Six: **protect the external voltage source, finish building the power supply, test the power supply, and creative additions to the power supply.**

Part One (Optional) – Protect the external voltage source (Optional)

It can be difficult to actually test that your circuit is working, since this involves using dangerous voltages in the lab. However, your simulation results should have let you determine whether the external voltage source was able to discharge to ground, without damaging your power supply.



You may want to show your design to your TA before you begin soldering.

Build the circuit into your power supply (on both channels).

Part Two – Finish building the power supply

Now is the time to wrap up any loose ends and fix any circuits that do not work like you want them to. You should use this time to make sure that the power supply is meeting all design constraints and that it will be able to past the testing phase.

Part Three – Test the power supply

Your TA will test your power supply when you are ready. You must have your power supply tested for full credit. If your design fails to pass this testing phase, then you may either accept partial credit, or fix your design and have it re-tested.

Part Four – Creative additions to the power supply

Part of the fun of designing and building your own circuits and projects is that they are unique and distinctly yours. This section will give you suggestions and ideas on how to improve or customize your power supply. You are encouraged, but not required to make creative modifications. Following are some of the creative modification suggestions to the power supply:

1. Paint your case to make it look cool or interesting. Show off your painting skills and artistic abilities.
2. Mount the cooling fan in a way that improves air flow. You can even use a fan with built-in LED lights or other features.
3. Add interior lighting. Case lighting is not just restricted to computers!
4. Use Plexiglas to allow people to see the circuits and inner workings of your power supply.
5. Add a receptacle to the back of the case, so that you can use a detachable power cord.
6. Add analog gauges to indicate output voltage and current. You can use a switch to select the channel being displayed on each gauge. See Figure for an example of a power supply that uses an analog voltage gauge.
7. The power supplies in the lab use seven-segment displays to indicate voltage and current digitally. Use your digital logic board and a four-digit, seven-segment display to indicate voltage and current. You will probably want to use a 3.5-digit A/D converter, rather than a simple serial or parallel output A/D converter. Output from a 3.5-digit A/D converter is already formatted for a base-ten number system, and is intended for this type of application. See Figure 14 for an example of a power supply that uses a digital display.



Figure 13: Analog voltage gauge



Figure 14: Digital voltage display

PRESENTATION

For the presentations:

- Each group of students will have one person present their design.
- The presenter will be chosen randomly.
- The **maximum time limit** for each presentation is: 12 minutes. (Up to 9 minutes for presentation, remaining for questions).
- The TAs will have tested the power supplies prior to the presentations.
- The presentation will be scheduled for the last 1.5 hours of the lab.
- Laptop, blackboard and overhead presentations will be acceptable.
- A room with a white or blackboard/ screen will be reserved and announced.
- Attendance by all the groups registered in the lab section is mandatory. (1% of the presentation grade is deducted for absentees).

The presenter (and the team indirectly) will be evaluated based on the following key elements of the presentation:

1. The presenter demonstrates a clear understanding of the design implemented.
2. If the design did not work for the team, the presentation highlights the steps that were taken to identify and fix the situation. If the "fix" did not work, the presenter provides an explanation of what the team would do next to troubleshoot, and why?
3. If the design was a departure from the standard schematic in the manual, the presenter is well-prepared with an explanation of how it works, and why it was chosen over the given schematic.
4. If the design specifications were changed, (by prior consent from the TA), then this is explicitly stated, and the altered design is discussed in the presentation.
5. The slides/ transparencies are clear and complete, and without grammatical errors in the text.
6. The presenter exhibits good speech delivery (such as: not looking at the floor, not talking to him/herself instead of to the audience, etc). For tips on how to present well, read *Appendix C: Presentation Pointers in this document*.
7. The presenter keeps to the time limit.
8. The presenter has the ability to answer questions from instructors, TAs and other peers present in the room.

TURN-IN

Student Name: _____

Lab Section Time: _____

<u>Test (from Project Specification)</u>	<u>Measurements</u>	<u>TA Signature</u>
<u>7.2.1 - EACH CHANNEL MUST BE CAPABLE OF SUPPLYING AT LEAST 900MA PER CHANNEL CONTINUOUSLY</u>		✓ _____
<u>7.2.2 - VOLTAGE OUTPUT BETWEEN ±2 AND ±12 VOLTS UNDER 900MA LOAD</u>		✓ _____
<u>7.2.3 - AN OVERLOAD TO LIMIT CURRENT TO ±1A ±10%</u>		✓ _____
<u>7.2.4 - SAFELY EQUIPPED WITH A COOLING FAN THAT SHOULD NOT NORMALLY BE RUNNING AT 70oF, BUT SHOULD REACH RATED SPEED AROUND 95oF</u>		✓ _____
<u>7.2.5 - DISCHARGES THE FILTER CAPACITOR ON EACH CHANNEL TO UNDER 3 VOLTS IN 5 SECONDS OR LESS WHEN THE MAIN POWER SWITCH IS TURNED TO OFF AND THERE IS NO LOAD PRESENT ON THE OUTPUT OF THE SUPPLY.</u>		✓ _____
<u>7.2.6 - EXTERNAL CONNECTIONS FOR LEADS AND VOLTAGE ADJUSTMENT</u>		✓ _____
<u>7.2.7 - ASSEMBLED SAFELY AND WITH NO ELECTRICAL HAZARDS</u>		✓ _____
<u>7.2.8 - VOLTAGE RIPPLE OUT OF EACH CHANNEL LESS THAN 0.75V PER CHANNEL WITH BOTH CHANNELS FULLY LOADED TO 900MA</u>		✓ _____

<p><u>7.2.9 - UTILIZES A SAFETY FUSE</u></p>		<p>✓ _____</p>
<p><u>7.2.10 - EASILY ACCESSIBLE AC POWER SWITCH</u></p>		<p>✓ _____</p>
<p><u>7.2.11 - A CLEARLY VISIBLE POWER INDICATION LIGHT</u></p>		<p>✓ _____</p>

APPENDIX A

Lab Equipment Overview

HOW TO USE A LAB POWER SUPPLY

Power supplies like the one shown in Figure 15 are easy to use, once the basics are understood. Use the supplies independently in this lab. Make sure both tracking buttons are in this setting.

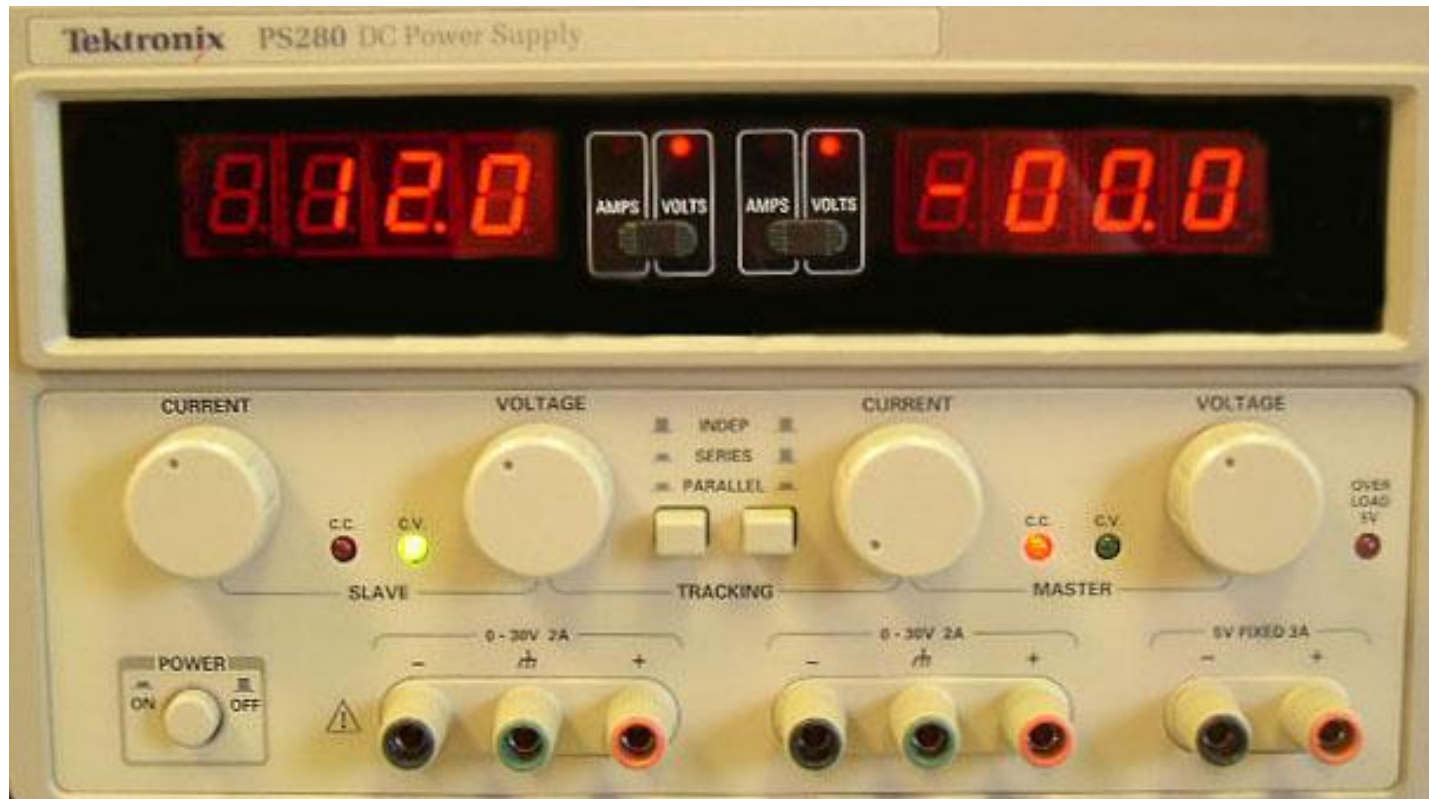

Figure 15: Tektronix PS280 DC Power Supply

Following is an explanation of the controls/ indications on the power supply;

1. **The “CURRENT” knob:** This sets the maximum current that the channel will source. This is also useful to prevent accidentally putting too much current through your circuit.
2. **The “VOLTAGE” knob:** This is used to select the output voltage that the supply will maintain.
3. **The “AMPS” and “VOLTS”:** The voltage and current being supplied can be read in the LED displays, by positioning the slider between “AMPS” and “VOLTS”.



The LED read-out may not be as accurate as you need. So, use a voltmeter to set the voltage if precision is required.

4. **The green “C.V.” light:** This means that a constant voltage is being supplied, and this is also the *desired condition* for the power supply.
5. **The red “C.C.” light:** This means that a constant current is being maintained, regardless of your voltage setting. This current is going to be the maximum current that you set with the “CURRENT” knob. If this light comes on, either fix your circuit, or increase the current limit to a more suitable value.
6. **Connectors:** Normally, you would use the red and black banana jacks to connect your circuit to the power supply. The green connectors are “earth grounds”, and they may be used as your ground. However, this is not usually required.



An earth ground is a connection to the planet Earth. The third prong of a power cord is also an earth ground.

Note: There are times when you need to supply a negative voltage. In this case, you would connect the red, positive connector to your circuit’s ground node. Then, attach the black, negative connector to the node where negative voltage is desired.

PSPICE NET-LISTS AND SIMULATIONS

Some people prefer to write their **net-lists** by hand, while others prefer to use the PSPICE schematic tool to create it for them. If you use the schematic tool to generate your lists, then you will need to edit the list to give it human-readable names. Let us suppose that you wanted to create a net-list for the simple circuit shown in Figure 16.

Follow these steps to create a net-list:

1. You would first need to draw the circuit as you did in *Electrical Fundamentals (I)* (ENGR 201).

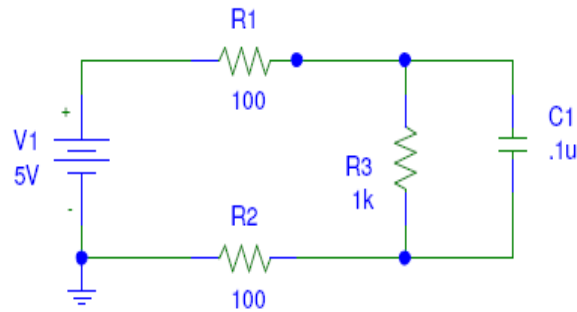

Figure 16: A very simple circuit

2. Run the **net-list** generator by selecting **Analysis** menu → Create **Net-list**. A *.net file will be created in the same directory as the schematic. The generated net-list is shown in Figure 17. This net-list contains computer-generated variables and is difficult to read and understand. However, a better (and preferred) approach would have been to manually create the net-list as shown in Figure .

```
* Schematics Netlist *
R_R3      $N_0002 $N_0001 1k
V_V1      $N_0003 0 5V
R_R2      0 $N_0002 100
C_C1      $N_0002 $N_0001 .1u
R_R1      $N_0003 $N_0001 100
```

Figure 17: Generated net-list

```
* simple_circuit.net
V1         3 0 5v
R1         3 1 100
R2         0 2 100
R3         2 1 1k
C1         2 1 .1u
```

Figure 18: Hand-created net-list

Create a net-list (Contd.)

3. A net-list is just the beginning of the process. Instructions must be given to indicate exactly what analysis you want performed on the circuit.



As an engineer, it is far more professional to be able to write your own net-lists that are neat and easy to read.

If you are not familiar with net-lists, then you may choose to have PSPICE generate your net-lists until you can remember how, but do not come to rely on this crutch.

4. Add these commands to your net-list.
5. Save it as a *.cir file.
6. Open this file with the program “**PSPICE AD Student**”. The simplest simulation of the circuit would be to run the file, as shown in **Error! Reference source not found.9**.

```
* simple_circuit.cir
* Basic analysis to find node voltages
.OP

V1      3 0  5V
R1      3 1  100
R2      0 2  100
R3      2 1  1k
C1      2 1  .1u

.probe
.END
```

Figure 19: A simple analysis

7. An output-file is generated once this circuit-file has been simulated. Create your own *.cir file.
8. Run the simulator.
9. Read the output-file and analyze/ observe the following:
 - (a) What kind of information is present?
 - (b) This kind of simulation is informative, but gets boring quickly.
 - (c) It would, therefore, be a lot more interesting if we could run the analysis with different values for the voltage source V1.

Create a net-list (Contd.)

10. The circuit shown in **Error! Reference source not found.**0 demonstrates several new concepts.

```
* simple_circuit.cir
* Basic analysis to find node voltages
.OP

V1      3 0  5V
R1      3 1  100
R2      0 2  100
R3      2 1  1k
C1      2 1  .1u

.DC V1 0 10 1
.print DC V(2)
.probe
.END
```

Figure 20: A more useful analysis

11. In Figure 20, notice the command “.DC V1 0 10 1”. This command does a DC sweep of the voltage source V1, starting at 0V and increasing to 10V in 1V increments.



A “DC sweep” refers to a type of analysis, where a DC voltage source has its value changed several times in one simulation. The command to do a DC sweep is “.DC”. It takes a starting voltage, an ending voltage, and the voltage by which to increment each time.

12. Also, in Figure 20, the last command added, “.print DC V(2)”, causes a print-out of the Node 2 voltages to the output-file. This type of the data output is useful to:

- (a) Find numerical values quickly.
- (b) Import the data into a different plotting program.

13. The output-file will now have the DC sweep values of V1 automatically included, so that you know which value of the Node 2 voltage corresponds to which V1 value. A graphical view of these values is often valuable.

14. Add a trace for “V1” and “V(2)” to the plot after the simulation is run, in order to see a graphical plot, or just input the values from the output-file into a separate graphing program.

15. The .print commands can be used just like a trace in the graphical output. You can measure both currents and voltages simply by adding additional parameters to the “print” statement. For example, you could add V(1), I(1), and I(2), to get the voltage and current for both Nodes 1 and 2.

SIMULATING SEMI-CONDUCTORS AND INTEGRATED CIRCUITS IN PSPICE

The PSPICE program contains information regarding only the most basic components, such as voltage sources, resistors, and capacitors. If you want to use a specific diode, transistor, or op-amp in your circuit, you must use a SPICE model.

A model is a long list of parameters that describe a complex circuit element in the basic components that SPICE can understand. For example, a real diode can be modeled as a voltage source, in series with a resistor. A detailed model will also include many of the *Device Physics* features that you learned about in *Electronic Materials and Devices* (ECE 317), such as junction capacitance.

The schematic entry tool has some basic libraries that it can use, so that you do not have to use the models. However, you would be lucky to find the exact device that you need. At best, you might find a similar device that you can use, in order to get a rough idea of how your circuit might perform. For example, the libraries contain models for a 1N4002 diode and a 2N3904 transistor, but you will be using a 1N4004 diode and a 2N4401 transistor. The 1N4002 can probably be used interchangeably, but the transistors will act slightly different.

Manufacturers often make SPICE models available for download, and this will probably be your most reliable source for SPICE models. An example of a 1N4004 diode PSPICE model is shown in Figure 21. You may find it easier to download this model from the Fairchild Semiconductor Web-site, rather than typing it in by hand.

```
* 1N4004 - 1A 400V General Purpose Rectifier
* -----
.MODEL 1N4004 D
+ IS = 3.699E-09
+ RS = 1.756E-02
+ N = 1.774
+ XTI = 3.0
+ EG = 1.110
+ CJO = 1.732E-11
+ M = 0.3353
+ VJ = 0.3905
+ FC = 0.5
+ ISR = 6.665E-10
+ NR = 2.103
+ BV = 400
+ IBV = 1.0E-03
```

Figure 21: Model of a 1N4004 diode

In Figure 21, pay particular attention to the line “.MODEL 1N4004 D”. This line tells you that this is a diode “D”, which you use by adding the name “1N4004” to the end of your part in the net-list.

See Figure 2222 for an example of a net-list that replaces R1 with a diode.

Notice that instead of pasting all the text of Figure 21 into the net-list, you can save it in a separate file, and then include it with the “.inc” command. Either method will work, but using “include” commands keeps your net-list-file readable, even when using monstrous models like the LM741 op-amp.

Also, notice that the net-list entry for D1 has the name “1N4004” after it, which tells PSPICE about the model to use for this device.

A diode only has two terminals, making it an easy device for which to create a net-list entry. The first net is the anode and the second is the cathode.

```
* simple_circuit.cir
* Basic analysis to find node voltages
.OP
.inc 1N4004.mod

V1 3 0 5V
D1 3 1 1N4004
R2 0 2 100
R3 2 1 1k
C1 2 1 .1u

.DC V1 0 10 1
.print DC V(2) V(1)
.probe
.END
```

Figure 22: Net-list using a model

Notice that the diode's name is "D1". This is because the 1N4004 model specifies the name "D" to be used with it. If you use a sub-circuit, then you must use an "X" name instead.

HOW TO USE THE TEKTRONIX CFG250 FUNCTION GENERATOR

In this section, you will be using a function generator as your small signal AC source. Figure 23 shows a Tektronix CFG250 Function Generator.



Be careful not to load the function generator by more than 10mA, as it is not designed to support large current loads.

To attach your function generator to the circuit, follow these steps:

1. Attach your BNC to alligator clips cable to the “Main” output connector of the function generator.
2. Set the “Volts Out” push button for the 0-2V or 0-20V range, depending on your voltage requirements.
3. Press the “Function” button corresponding to the waveform you need.
4. Press the “Range” button for the desired range.
5. Adjust the “Frequency” dial to the desired frequency.
6. Turn the power on to the function generator.
7. If your signal needs a DC component, pull out the “DC Offset” knob, and adjust it to the desired DC bias point. (Use your oscilloscope to measure the DC offset).
8. Adjust the “Amplitude” and the “Frequency” dials to the desired settings, while using an oscilloscope to precisely measure the output signal.
9. Attach the signal generator to your circuit.



Figure 23: Tektronix CFG250 Function Generator

APPENDIX B

Project Design Specification Document

DOCUMENT OVERVIEW

Modern engineering requires groups of engineers to work together, possibly across large distances, to develop sophisticated systems. In order for all of the parts of a project to work together, a project specification document is vital. Development of a project specification document is *always* the first step in any project. Unless all engineers working on the project have the same understanding of the project pieces, the final result will not function.

Project specification documents come in many a varied format/ outlook. Sometimes they will be formal written documents like those submitted for patent approval. Other times they may be ‘back of the napkin’ sort of documents that give only the briefest explanation, but help an engineer to stay focused. For this course, you will be writing a project specification that is somewhere between the two. You will have a formalized structure to follow, including typographical layout and document length.

It is important to realize that in many of the courses you will be taking up in later terms, you will be asked to produce design specifications. The sections and content may vary slightly for each course: so, pay attention to what is asked for, in the requirements. For example, in your *Senior Design* course, you will be asked to write a very in-depth design specification for your final project. Remembering what you have done in these early courses will dramatically improve your success during the senior design implementation.

DEVELOP THE PROJECT SPECIFICATIONS

When developing any project specification, a few general steps should be taken. In order to make a complete design, use these basic guidelines:

- Conduct a technology review.
- Come up with a top-level design.
- Outline the testing process.

Conduct a technology review

The first step in developing the project specifications is to review the ‘state of the art’, which is more commonly called a **technology review**. This can be achieved thus:

- Find projects similar to yours.
- Review other similar projects.
- Tabulate the results with a comparative analysis.

- Make final analytical conclusions from the review.

Find projects similar to yours

This first step involves finding similar projects and digging into them to **see how they were accomplished**. Often times, this could be combined with a market analysis as well, if the project will result in a product to be sold.

When working on a new project, you may find that there is nothing on the lines of what you want to design, in existence yet. (This is a good thing, since it means you have something no one else has, and can set your own standard for it.) But, it also means that you cannot make a direct comparison. However, you are most likely to find at least one other project that has some of the same aspects for your comparison. For example, you might not be able to find many examples of three-phase power generators; but, DC generators have a lot of similarities.

Review other similar projects

Ideally, you should review an infinite number of projects that help you to understand what others have done, but infinity is an awful big number. As a rule of thumb, the more the better, and the more complex the problem, the more projects to compare that are necessary. For the simple project in this course, **five to six projects** should be sufficient. If you are having trouble finding projects to review, be sure to search projects under the topics of commercial products, student projects, large scale generators, and the like.

Tabulate the results with a comparative analysis

Once a full technology review has been conducted, you should be able to generate a table that has your project as well as the other reviewed projects together. The table should have **key information that allows you to compare them**, in the method “apples to apples *and* oranges to oranges.” For example, if there is a power generator project that has information on cost, size, output watts, and method of generating power, you can compare your project with that, using the same parameters.

Make final analytical conclusions from the review

Using all of this information you should be able to decide on the **features and design trade-offs** required, so that you can explain your project specification. It is important that all of your design choices are backed by solid facts and reasoning, and that you understand the basis of the analysis that you are using to make each decision.

This is a powerful tool, because if any of your base assumptions are changed by new information, you can quickly revise any decisions that were made, to conform to the new information.

Come up with a top-level design

Any design can be broken down into three components: **inputs, outputs, and function**. To come up with the final design, follow these steps:

- Start with a generic design.
- Remove any ambiguity.
- Split the generic design into more well-defined components.

Start with a generic design

This simple idea can be easily (and often is), represented as a block diagram like the one in Figure 1.

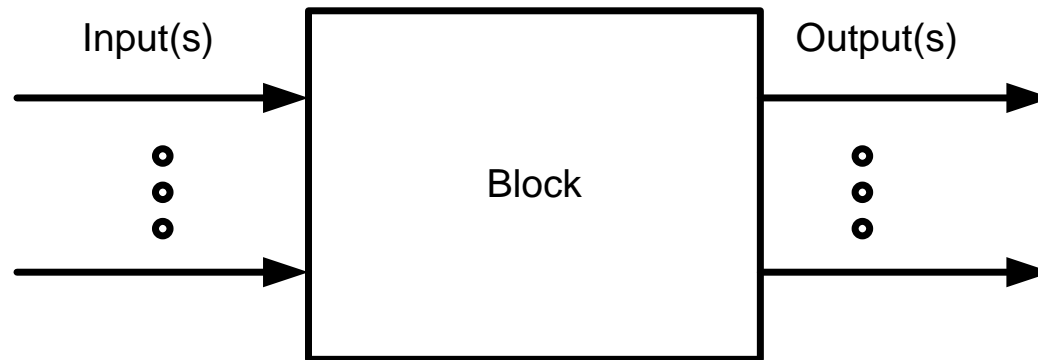

Figure 1: Generic design represented in a block diagram

This simple design could have any number of inputs and any number of outputs. Its function could be defined as simply as, “**Definition I:** Input 1 is added to Input 2, and is sent to Output 1.” However, its function could also be as complex as, “**Definition II:** Input 1 will be used to power the system.”

Remove ambiguity

In the above definitions, even though the number of words in the description is about the same, the amount of ambiguity in Definition II is much larger. This ambiguity is what leads to mistakes and differences between what two engineers design. For example, if one engineer assumes that the system will be supplied with 1000W of energy, and another engineer assumes they only need to supply 10W of energy, nothing will work well or as expected.

Split the generic design into more well-defined components

To illustrate how you could make a generic design more well-defined, consider the design for a generator. For a generator, you might start with a block diagram like the one in Figure 1. This diagram is the simplest one that could be produced. From this simple diagram, you should use ‘top down design’ to split it into smaller and smaller more well defined components. These smaller components allow you to specify every piece of your design clearly and concisely.

Description: The generator block accepts motion input, and through magnetic coupling, generates a voltage and current capable of charging a portable device identified by the designer.		
Signal Name	Direction	Description
Motion	In	This is the energy input to the system.
		Motion
	:	Rotational
		Min. Speed: 100 RPM
		Max. Speed: 2000 RPM
		Nomin

Figure 2: Example of a design with well-defined components and their descriptions

The question that rises is: **How do you know when to split a component-block into further components?**

You should split any component-block that you cannot fully understand how to implement, into further components. For example, you may not know how a digital wrist watch performs. However, once broken into its individual parts, such as: display, crystal, buttons, state machine, casing, battery, etc, you might find it easier to understand. If one of those pieces is ambiguous, you would again further split it down in more sub-components, to get a more complete picture.

Outline the testing process

The final yet very important section of the design specification is explaining **how the project will be tested**, to ensure that it meets the requirements and goals defined in the project specification.

This could involve outlining the following qualitative/ quantitative testing procedures/ requirements:

- Measurements.
- Long-term usage.
- Destructive testing
- Others.

The tests that are chosen will be depend on and determined by the project. By and large, these tests are very simple.

For example, if a requirement for a design is that the device be portable, the test for this might be: “The team will ensure device portability by having one member of the team pick the device up and move it across the room.” Or, you could instead specify it as: “The device will not weigh more than 20 pounds, and will not be larger than 12”x12”x12”.”

APPENDIX C

Presentation Pointers

OVERVIEW

The purpose of any form of *technical communication* is to inform, not impress. Classes that need students to give a *technical* presentation, actually require one that falls in the genre of *formal* presentation. This document falls in the same genre too. In addition, there is sometimes the requirement for the student to submit the written matter of that presentation in hard or soft copy. This document is therefore intended to help you with some basic tips to refine the outlook of a technical presentation, both for the presenter as well as for the presenter's document. Use them as guidelines and the result will be a well-prepared, well-presented, professional presentation.

OBJECTIVES

Any formal presentation has the following key features that presenters need to focus on:

- Writing the document to be submitted for the presentation.
- Outline of the presentation content/ slides.
- Communicating effectively through presentation media.
- Dressing right and using the right body language for the presentation.

Writing the document to be submitted for the presentation

Assuming that you have researched the presentation subject very well, and have sufficient and relevant presentation matter, write/ type a rough draft and then refine it as you progress.

The tips for the written material (that you would submit at the end of the lab) include:

- Outline of the document content.
- Content of the document.
- Language of the written document.

Outline of the document content

The outline of the document (i.e. introduction/ body of the document/ conclusion), are explained later in this document under the section: *Outline of the presentation content/ slides*.

Content of the document

The content of the document would be similar to what you present in class as well. Following are some quick tips to start you on the content of the document, as well as on the slides:

1. **Make a rough draft:** Write down a synopsis of your goals, which would essentially be the purpose of the document.
2. **Research the goals:** Use reliable Internet resources/ the Library/ conduct surveys or interviews and get valid information to support your goals.
3. **List five important facts:** Depending on the length of the document, select any five goals/ concepts on which to focus the basis of your document, and arrange them in order of chronology/ priority.
4. **Add appropriate visuals:** A picture is worth a thousand words. Any part of the document text that can be replaced/ enriched with a visual will create more impact than just plain-text.
5. **Cite all your resources:** Check all author-date citations and all entries in the reference list for both accuracy and conformance to the format being imposed for your document.
6. **Proofread:** Use the spell-checker and/ or have a friend peer-edit the document before submission.

Language of the written document

Each document has a voice. Here are a few tips to observe, in order to ensure the language is not offensive or ambiguous:

1. Use a clear and informal style, avoiding unnecessary jargon and acronyms. Acronyms can be used when it is understood by both the audience and the writer.
2. Preferably, use the first person and active voice.
3. Avoid language that might be construed as sexist/ racist/ politically incorrect.
4. Analyze the audience (international/ multi-cultural/ academic diversity). For an in-class, technical presentation/ submission, the presenter typically does not need to worry about the nature of the audience, but this is a handy tip that most presenters tend to overlook.

Outline of the presentation content/ slides

These tips are of paramount importance to forming a powerful outline for any technical document and/ or presentation slides:

1. **Start with a welcome-slide.**

The first slide welcomes the audience, (and it is worthwhile to make a mention of notable attendees), and then introduce yourself. (This would conform to the cover-page of your written document).

2. **Spell out your conclusion or summary first.**

Most people attending a presentation will "remember" no more than five concepts. Ideally, the presenter should have a list of the five most important points/ concepts/ facts that should be remembered. This introduction with the concepts should **spell out the agenda** for your presentation. Giving your audience a framework of understanding at the beginning allows them to easily integrate information into their knowledge, because they already have a 'place to put that information.'

3. **Highlight the main concepts, using visuals and minimum text.**

- a) Use an 18-point (or higher) font size for your slides. Also, use an appealing but light-and-bright solid background color for the slides.
- b) From the above-mentioned five primary concepts, allocate an average of two slides of text to each main concept.
- c) Have about four to five key points for each concept.
- d) Write these key points briefly in short one-liners, and elaborate on the points in the speech instead.
- e) **About three visuals** for the entire presentation should be sufficient, as long as they give appropriate and complete backing to the associated content.
- f) Too much information, small-size text, and unclear visuals renders the presentation less effective in terms of message-delivery.

4. **Cite any sources** for visuals/ text, by mentioning it verbally or including it on the slide, in a smaller footer area..

5. **Have a strong conclusion.** Make the closing short and sweet. Re-iterate the three dimensions of your message (what, why and how) in a powerful one-slide finale to the presentation. A good rule of thumb is to use 10-15% of your time for the *opening* and 5-10% for the *closing*.

6. **Question-time.** Make the discussion open to questions from the audience after your closing. Answer the questions as briefly and concisely as you can. It is best to paraphrase the question before answering it, to clarify it in your mind and to make sure you understand the question. If you do not know the answer, say so. Do not try to make one up.

Communicating effectively through presentation media

To make your presentation more than just a stand-up speech with the whiteboard and markers as your tools, add pizzazz to your presentation by taking advantage of the multimedia tools. **Confirm with your professor/ TA as to what multimedia will be available for that day/ classroom.** Any of the following will make your presentation more effective:

If a computer will be available for your presentation, digital slides maybe a good choice for your presentation. However, make an intelligent decision because if slides are not needed or are an ‘overkill’ for your presentation, do not endanger your presentation by using them.

If you do decide to make digital slides, bear these guidelines in mind:

- **Use Microsoft PowerPoint or even Adobe PageMaker:** These are ideal for adding color, background theme, convenience and dynamic appeal to your presentation.
- Read and use the tips mentioned in the previous section, “*Outline of the presentation content/ slides*”, to create your PowerPoint slides.
- **Confirm with your professor/ TA regarding what storage media (i.e. USB mass storage removable disk, CD, etc) you can use, and/ or if you can bring your own PC-notebook, or if there is wireless network access, with which to launch your PowerPoint presentation.**
- Allow the audience at least half to one minute to read a slide with important, concise, bulleted points and stress or elaborate on them verbally.
- Do not read your slides for your audience, because they can usually do that themselves. Instead, use your time to maximize impact by elaboration or descriptions and examples.

Dressing right and using the right body language for the presentation

The document and slides are not the only aspects for the presentation. In order to be effective in delivering the message, the presenter needs to bear in mind a few key-points as well. This has to do with dressing appropriately and using the right body language.

The ideal way to present yourself successfully is to use the three main components of person-presentation, commonly called **the three Vs: Visual, Vocal, and Verbal**.

Visual

The first thing your audience members see is your appearance. Your body language will also send the audience a message. Before you get a chance to say a word, some of them will already have judged you based solely on how you look. Your visual outlook therefore comprises of your *attire* and *body language*.

Tips for presentable *attire*:

- You can never be faulted for looking "too professional," even if the audience is dressed down.
- Formal clothing makes the audience accord you respect.
- Comfortable clothing helps the presenter to move around easily.
- Be certain that your outfit and accessories do not detract the audience from your presentation.
- Avoid anything that makes noise or looks flashy, like jangling bracelets or earrings.
- Avoid having money and keys in the pockets, especially if you have a tendency to put your hands in the pockets.

Tips for using the right *body language*:

- Do not cross your arms or fidget.
- Use gestures to emphasize points, but be careful not to flail your arms around.
- The most effective stance is a forward lean, *not* swaying back and forth or bouncing on your feet.
- Make regular eye contact with audience members, holding the connection to complete an idea. Look around with a panoramic view while you speak. Effective eye-contact helps draw listeners into your speech.
- Nodding to emphasize a point also helps make a connection with the audience. If you nod occasionally, audience members will too -- creating a bond.

Vocal

If you have ever listened to people speaking in a monotone, or too softly, you know how difficult it is to pay attention. There are six *vocal cues* to remember: pitch, volume, rate, punch, pause, and diction.

- **Pitch and volume:** It is very important to speak loud, clearly and enunciate. When you look down, your voice drops.
- **Rate:** If you rush your delivery, the audience will have to work too hard to pay attention. Vary your tone and speed and tailor your delivery rate to accommodate any regional differences. Keep your chin up while speaking, and do not bury it in note-cards.
- **Punch and pause:** Emphasize or "punch" certain words for effect, but do not forget to incorporate pauses to give the audience time to let important points be understood.
- **Diction:** Proper diction is also essential; if you are not sure how to pronounce a word, look it up or do not use it.

Verbal

There are three *verbal communication rules* to remember:

- Use descriptive and simple language.
- Use short sentences.
- Avoid buzz-words and jargon.

Video-tape your presentation or practice in front of a friend. Watch your expressions, body language, vocal and verbal delivery, and your confidence level. See if you have smiled enough and in appropriate places.

CONCLUSION

As with most documents, this document re-caps the main points to remember for the final presentation:

1. **Know the purpose, audience, and logistics** (such as time-limit for presentation, whether each member talks or just a team representative talks, and the visual equipment available for the presentation).
2. **Prepare and research adequately** (with an opening that creates impact, and a closing that ends with strength).
3. **Create a user-friendly draft** (that makes use of the available multimedia, such as PowerPoint presentation).
4. **Most important of all: PRACTICE WELL prior to giving your presentation.** (Video-tape yourself or envision a set-up similar to the presentation while practicing the speech delivery).
5. **Arrive early** (to meet up your team, check that the visual equipment works, go over the slides).
6. **Apply the delivery techniques** as a presenter (visually, verbally and vocally).
7. **Handle questions and answers with tact.** (Stick to the time-limit, so that there is time for the Q&A session).

8. **Be confident** (especially after you have read and applied the above techniques for an excellent presentation)!

REFERENCES

Following is a list of sources that were referred to extensively, in the making of this document. You are encouraged to refer to these sites, for more presentation pointers, apart from those outlined in this document.

1. Society for Technical Communication
<http://www.stc.org/>
2. The Art of Communicating Effectively
<http://www.presentation-pointers.com/>
3. National AV supply
<http://www.nationalavsupply.com/>
4. Chicago Manual of Style
<http://www.libs.uga.edu/ref/chicago.html>

APPENDIX D

Tektronix TDS 210 Oscilloscope

SECTION OVERVIEW

This document gives you an overview of the functions of the **Tektronix TDS 210 Oscilloscope** used in the ENGR 201 - 203 labs. It also shows you how to properly connect the oscilloscope with your circuit to measure different quantities. You will notice that the oscilloscope is often referred to in lab as well as in lab manuals as **‘scope’ or sometimes ‘oscope’**.

 Read the lab handout *The Oscilloscope* first, to understand the meanings of the terms used in this guide, specific to the **Tektronix TDS 210 oscilloscope**. Most of the information presented in this handout is taken from the manual *Tektronix Oscilloscope TDS 210*.



Read the section on **Safety** carefully, and make sure you understand every detail. Overlooking or not bearing in mind the safety precautions explained in the **Safety** section could cause severe property damage and can also be hazardous to you.

SYMBOLIC REPRESENTATION

Similar to all other devices in electrical engineering, there also exists a standard symbol (including alternative symbols) for the oscilloscope in schematics. Unfortunately, this symbol is not widely used, nor is it easy to recognize. The symbol used for the oscilloscope in the documents and handouts for ENGR 201 and 202 is shown in Figure 1. The symbol shows a circle (as with all other measuring devices), and two vertical lines representing the two vertical plates in a tube of an analog scope. Figure 2 shows the BNC-connector for one channel and the corresponding terminals.

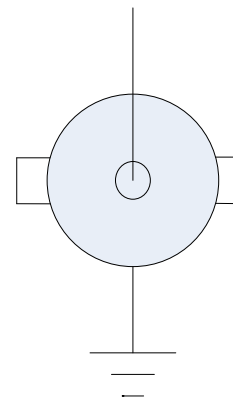
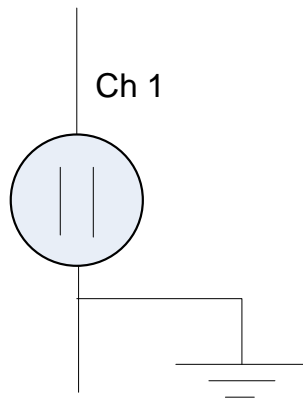

Figure 1: Symbol for an oscilloscope

Figure 2: BNC-connector on an oscilloscope

SAFE USAGE OF THE OSCILLOSCOPE

Although the oscilloscope measures the voltage between two terminals as any multimeter does, there are important differences between oscilloscopes that are: (i) attached to the power grid, and (ii) stand-alone, battery-powered multimeters. The ground wires of the inputs (channel, trigger, etc.) are internally connected together. The ground wires are connected (hard or soft) to the earth ground of the power source.



You should always assume that the grounds of the BNC-connectors (outer metal part) on the scope are connected together and most likely connected to the earth ground of the power source. This also applies to the BNC-connectors of the function generator.

A **hard connection** to the earth ground of the power source means that the ground is connected directly to the earth. A **soft connection** means that an internal circuit makes sure that the ground and the earth are on the same voltage level, but has no direct connection. This internal connection of the grounds restricts what voltages you can measure in a circuit.



Before making connections to the input or output terminals of the oscilloscope, ensure that the oscilloscope is properly grounded.

Following are the **connections** that you can or cannot make, using the oscilloscope:

1. You can only measure voltage levels with reference to a common ground in the circuit, (as shown in Figure 3), i.e. you **can** only measure the voltages on the nodes as defined for the node voltage method referenced to ground, but you **cannot** directly measure the voltage between any two nodes, (as shown in Figure 4).

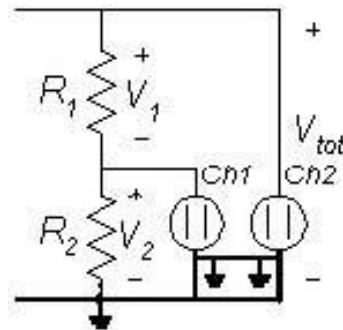

Figure 3: Correct connection, since the ground node in the oscilloscope is the same as in the circuit

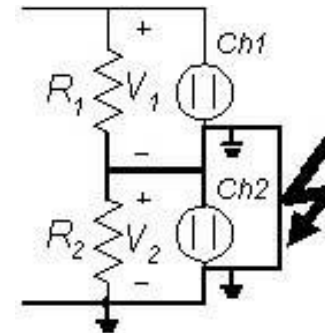

Figure 4: Faulty connection, since the ground node in the oscilloscope short circuits the resistor R2 with the Ch 2 ground connection to V2

Oscilloscope connections (Contd.)

- If you connect a function generator or a second oscilloscope to your circuit, you have to use the same common ground for all instruments, (as shown in Figure 5). You cannot connect the oscilloscope to a different ground as the ground of the function generator, (as shown in Figure 6).
- The connection shown in Figure 6 is the most dangerous one, because you will be involving the power supply in the fault connection that causes a large fault current. The least danger that can be caused as a consequence of this fault current is that it will trip the circuit breaker or blow a fuse, but it can also cause a greater damage such as melting the ground connection and causing damage to the scope or even to you.

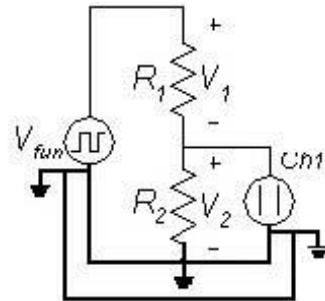

Figure 5: Correct connection, since the ground node of the oscilloscope and function generator (solid line) is the same as in the circuit (dashed-line)

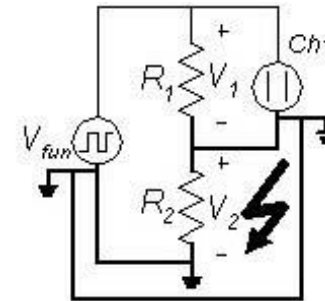

Figure 6: Faulty connection, since the ground node of the oscilloscope and the function generator is connected to V2 by the Ch 1 ground connection

If it is necessary to measure the voltage across R1 in Figure 2 to Figure 6, you have to make a 'differential measurement' and use the math functions that are provided by the oscilloscope. In order to do so, connect the oscilloscope as shown in Figure 3 and subtract the two measured voltages, i.e. $V_I = V_{Ch2} - V_{Ch1}$.

Because of the connection between the circuit ground and the earth ground of the power supply, there are other related issues that you have to consider, such as the floating ground.



If you are working with power circuits, transformers or systems with several different ground nodes, you have to be especially careful. Refer to a manual of your equipment for further explanation. .

FUNCTIONAL CHECK

Perform this quick functional check to verify that your instrument is operating correctly.

Step I

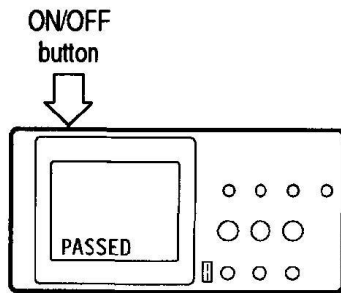

Turn on the instrument.
Wait for the confirmation that any and all self-tests have passed.

Step II

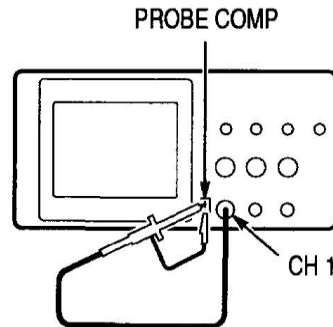

Connect the oscilloscope probe to Channel 1.
Attach the probe tip and reference lead to the PROBE COMP connector.

Step III

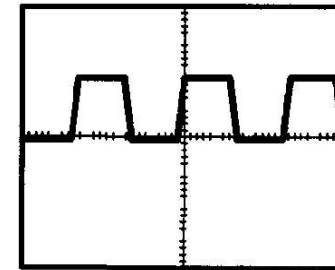

Push the AUTOSET button.
Within a few seconds, you should see a square wave in the display, (which is approx. 5V at 1 kHz).
Repeat Steps II and III for Channel 2.

PROBE COMPENSATION

Perform this adjustment to match your probe to the input channel. This should be done whenever you attach a probe for the first time to any input channel.

Step I

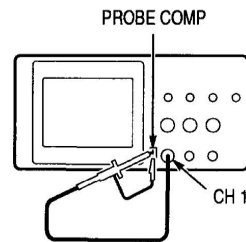

Perform a functional check for the channel to which the probe is attached.

Make sure that the probe is properly connected to the PROBE COMP connector.

Step II

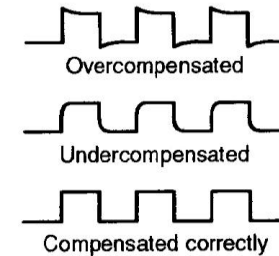

Check the shape of the displayed waveform.

If necessary, adjust your probe by turning the small screw on the probe. (This adjusts the RC time constant of the probe by varying C).

OPERATING BASICS

The front panel, as illustrated in Figure 7, is divided into a number of functional areas. This section provides you with a quick overview of the controls and the information displayed on the screen.

The operating basics are divided into the following sub-sections: **display area, vertical controls, horizontal controls, trigger controls, connectors, and control buttons.**

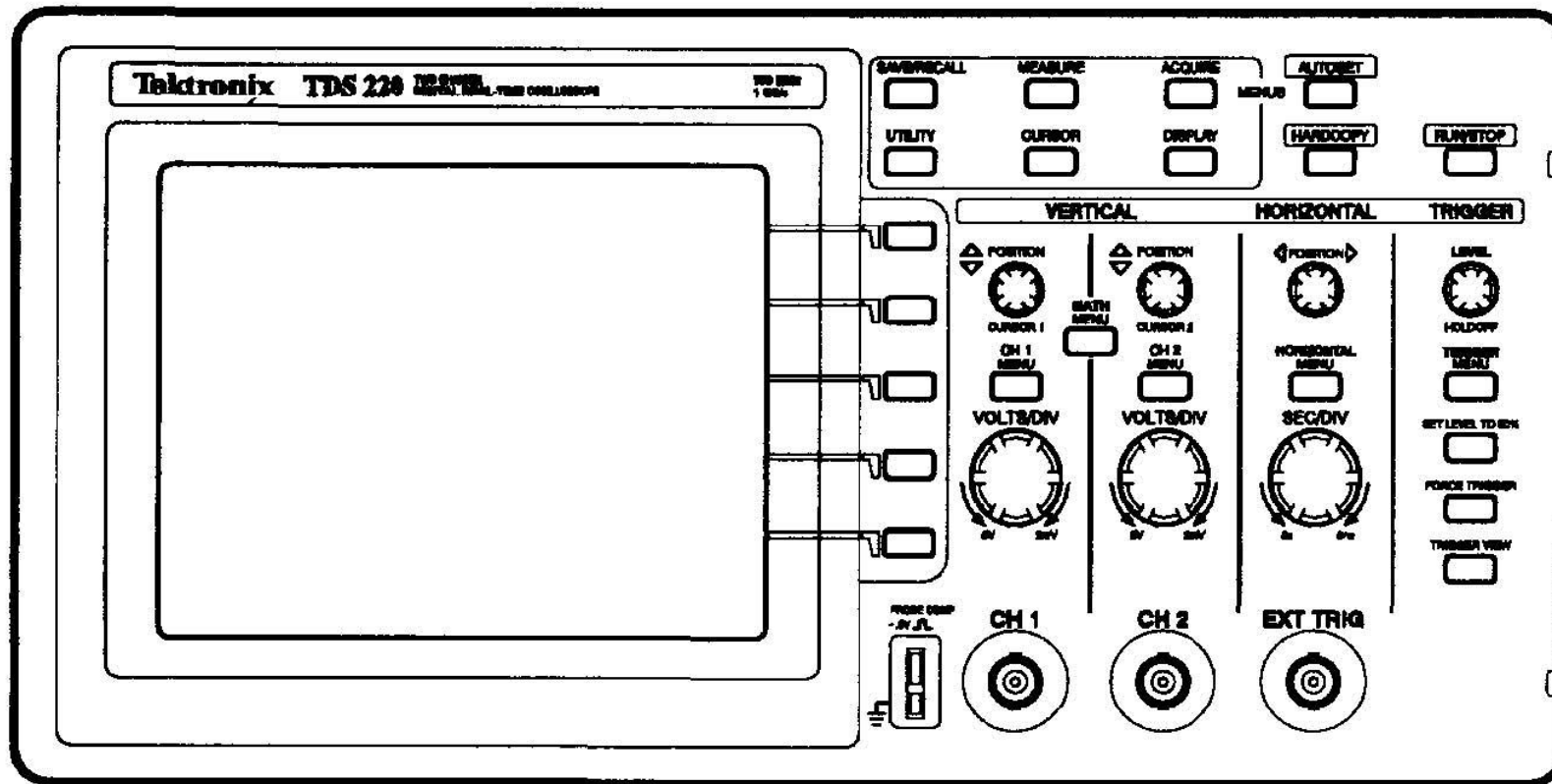

Figure 7: Front panel of Tektronix oscilloscope TDS 210 and TDS 220

Display Area

In addition to displaying waveforms, the display area provides detailed information about waveforms as well as instrument control settings. The display area is detailed in the following sub-sections: **waveform display** and **display modes**.

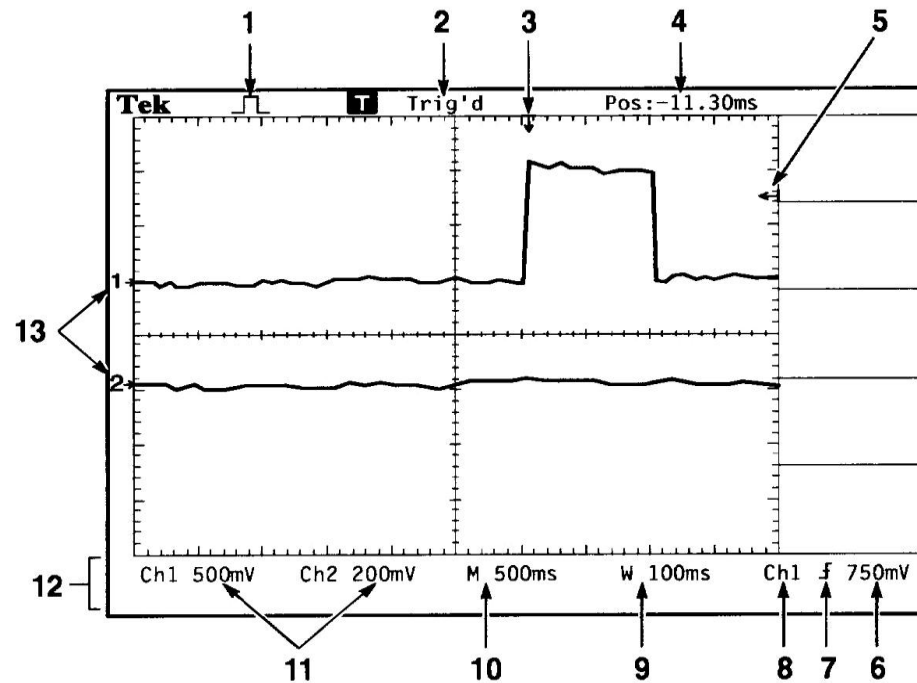

Fig. 8: Display area

Waveform display

Depending on the type, waveforms will be displayed in three different styles: black, gray, and broken.

Black indicates a live waveform display.

Gray indicates reference waveforms and waveforms with persistence applied.

Broken indicates the waveform display accuracy is uncertain.

Display modes

Following are some of the features of the display modes:

- **Icon** display indicates:
 - Acquisition mode, (which could be sample, peak detection or average mode).
 - Selected trigger slope for edge triggering.

- **Trigger** status indicates:
 - If there is an adequate trigger source, or if the acquisition is stopped.
 - Indicates the difference (in time) between the center graticule and the trigger position.

- **Center** screen:
 - Equals zero.

- **Marker** status indicates:
 - Horizontal position, since the Horizontal Position control actually moves the trigger position horizontally.
 - Trigger level.

- **Readout** status indicates:
 - Numeric value of the trigger level.
 - Trigger source used for triggering.
 - Window zone timebase setting.
 - Main timebase setting.
 - Channels 1 and 2 vertical scale factors.

- **On-line messages:**
 - Displayed in the display area momentarily.

- **On-screen markers:**
 - Show the ground reference points of the displayed waveforms. (If there are no markers, it means that the channel is not displayed).

Vertical Controls

The following table details the usage for the vertical controls of the oscilloscope:

<u>Control</u>	<u>Usage</u>
CH1 (CH2) and CURSOR 1 (2)	Vertically adjusts the channel 1 (2) display, or positions cursor 1 (2).
MATH MENU	Displays the waveform math operations menu.
CH1 (CH2) MENU	Displays the channel input menu selections and toggles the channel display on and off.
VOLTS/DIV (CH1 and CH2)	Selects calibrated scale factors.

Figure 9 illustrates the vertical controls of the oscilloscope.

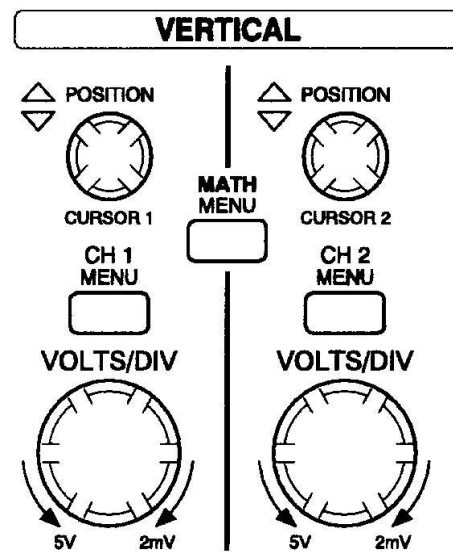

Figure 9: Vertical controls

Horizontal Controls

The following table details the usage for the horizontal controls of the oscilloscope:

<u>Control</u>	<u>Usage</u>
POSITION	Adjusts the horizontal position of all channels.
HORIZONTAL MENU	Displays the horizontal menu.
SEC/DIV	Selects the horizontal time/div (scale factor) for the main time-base and the Window Zone.
VOLTS/DIV (CH1 and CH2)	Selects calibrated scale factors.

Figure 10 illustrates the vertical controls of the oscilloscope.

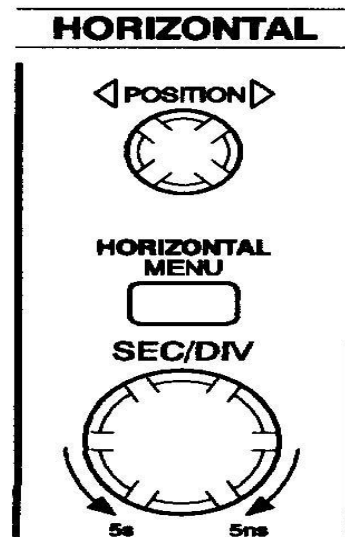

Figure 10: Horizontal controls

Trigger Controls

The following table details the usage for the trigger controls of the oscilloscope:

<u>Control</u>	<u>Usage</u>
LEVEL AND HOLDOFF	<p>This control has a dual purpose which is defined in the Horizontal Menu system.</p> <p>As a trigger control, it sets the amplitude level that the signal must cross to cause an acquisition.</p> <p>As a holdoff control, it sets the amount of time before another trigger event can be accepted.</p>
TRIGGER MENU	Displays the trigger menu.
SET LEVEL TO 50%	The trigger level is set to 50% of the signal level.
TRIGGER VIEW	Displays the trigger waveform in place of the channel waveform, while the TRIGGER VIEW button is held down.

Figure 11 illustrates the vertical controls of the oscilloscope.

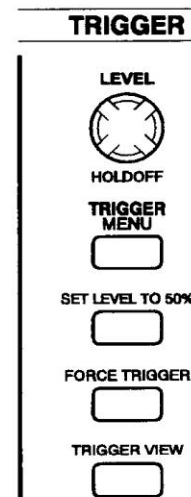

Figure 11: Trigger controls

Connectors

The following table details the usage for the connectors of the oscilloscope:

<u>Control</u>	<u>Usage</u>
PROBE COMP	<p>Voltage probe compensation output and ground. Use this to electrically match the probe to the input circuit. Refer to second section.</p> <p>⚠ The probe compensation ground and BNC shields are connected to earth ground. Do not connect a voltage source to these ground terminals.</p>
CH1 and CH2	Input connectors for waveform display.
EXT TRIG	Input connector for an external trigger source. Use the Trigger menu to select the trigger source.

Figure 12 illustrates the vertical controls of the oscilloscope.

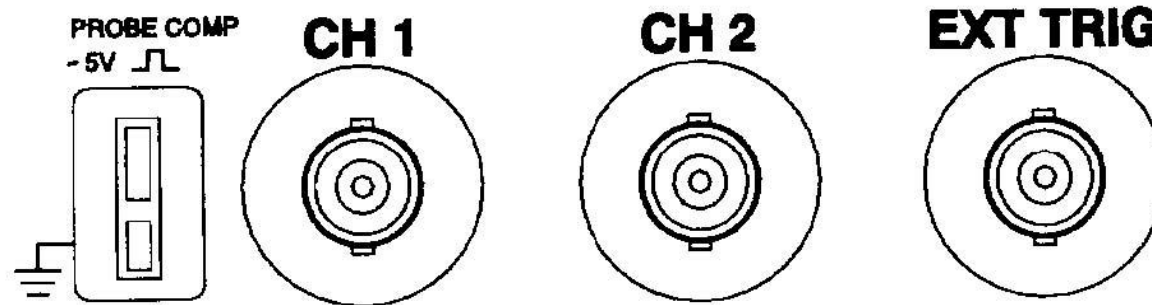

Figure 12: Connectors

Control Buttons

The following table details the usage for the connectors of the oscilloscope:

<u>Control Button</u>	<u>Usage</u>
MENUS	Some of the control buttons under “Menus” are explained in this table.
AUTOSET	Automatically sets the instrument controls to produce a usable display of the input signal.
HARDCOPY	Starts printing operation if a printer is attached to the oscilloscope.
RUN/STOP	Starts and stops waveform acquisition.

Figure 13 illustrates the control buttons of the oscilloscope.

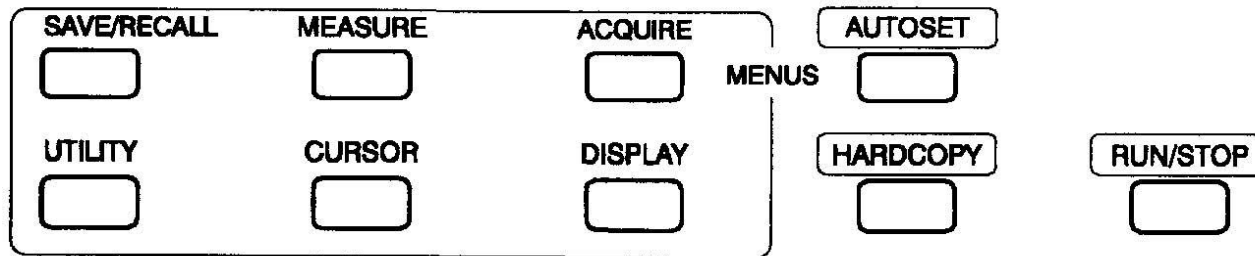

Figure 13: Control buttons

REFERENCE

Use this section to as a detailed reference for the following controls / settings: **Autoset, Vertical, Display, Trigger, Math, Measure, Cursors** and **Acquire**.

Autoset

The Autoset feature automatically adjusts controls to produce a usable display of the input signal. Pushing AUTOSET adjusts or sets each of the items listed in the following table:

<u>Function</u>	<u>Setting</u>
Acquire mode	Sample
Vertical coupling	DC (if GND was selected)
Vertical VOLTS/DIV	Adjusted
Bandwidth	Full
Horizontal position	Centered
Horizontal SEC/DIV	Adjusted
Trigger type	Edge
Trigger source	Lowest numbered channel displayed
Trigger coupling	Adjusted to DC, Noise Reject, or HF Reject
Trigger slope	Rising
Trigger holdoff	Minimum
Trigger level	Set to 50%
Display format	YT
Trigger mode	Auto

Note: If your oscilloscope does not have an AUTOSET function, you have to set these items by hand.

Vertical

You can use the vertical controls to display waveforms, adjust vertical scale and position, and set input parameters. The vertical menu contains the items listed in the following table, for both Channel 1 and Channel 2. Each item is set individually for each channel.

<u>Menu</u>	<u>Settings</u>	<u>Comments</u>
Coupling	DC	DC: Passes both AC and DC components of the input signal.
	AC	AC: Blocks the DC component of the input signal.
	GND	GND: Disconnects the input signal.
BW Limit	20 MHz	Limits the bandwidth to reduce display noise.
	Off	
Volts/Div	Coarse	Selects the resolution of the Volts/Div knob.
	Fine	
Probe	1x	Selects the appropriate setting to match your probe attenuation factor, which in turn makes the vertical scale readout correct.
	10x	
	100x	
	1000x	

Waveform off: To remove a waveform from the display, push the CH1 MENU or CH2 MENU button to display its vertical menu. Push the menu button again to turn the waveform off.

Display

Push the DISPLAY button to choose how waveforms are presented as well as to change the appearance of the entire display.

<u>Menu</u>	<u>Settings</u>	<u>Comments</u>
Type	Vectors	Vectors: Fills the space between adjacent sample points in the display.
	Dots	Dots: Displays only the sample points.
Persists	OFF	
	1 sec	
	2 sec	Sets the length of time for which each displayed sample point remains displayed.
	5 sec	
Infinite		
Format	YT	YT: Displays the vertical voltage in relation to time (horizontal scale).
	XY	XY: Displays Channel 1 in the horizontal axis and Channel 2 in the vertical axis.
Contrast Increase		Changes contrast (increasingly).
Contrast Decrease		Changes contrast (decreasingly).

Trigger

Two types of triggers are available: edge and video. For the lab, only edge triggering is used and therefore it is the only one explained in this manual as well.

Video triggering is used to trigger on lines of fields of a NTSC, PAL, or SECAM standard video signal. **Edge triggering** is used to trigger on the edge of the input signal at the trigger threshold.

<u>Menu</u>	<u>Settings</u>	<u>Comments</u>
Edge		With Edge highlighted, the rising or falling edge of the input signal is used for the trigger.
Slope	Rising Falling	Select either option to trigger on either the rising or the falling edge of the signal
Source	CH1 CH2 EXT EXT/5 AC Line	Select the appropriate input source as the trigger signal. Select the type of trigger signal
Mode	Normal Auto Single	Normal Mode: To trigger only on a valid trigger. Auto Mode: To let the acquisition free-run in the absence of a valid trigger. Single Mode: To capture a single acquisition of an event. The content of a single acquisition sequence depends on the acquisition mode (i.e. sample , peak detect or average mode).
Coupling	AC DC Noise Reject HF Reject LF Reject	Select the components of the trigger signal applied to the trigger circuitry.

AC Line Source: The AC Line trigger source uses the power signal as the trigger source. Trigger coupling is set to DC and the trigger level to 0V.

Math

Push the MATH MENU button to display the waveform math operations. Push the MATH MENU button again to turn off the math waveform display.

<u>Menu</u>	<u>Comments</u>
CH1-CH2	Channels are subtracted from each other.
CH2-CH1	Channels are subtracted from each other.
CH1+CH2	Channels are added together.
CH1 invert	Channel 1 is inverted. (However, it cannot be inverted if Channel 2 is inverted as well).
CH2 invert	Channel 2 is inverted. (However, it cannot be inverted if Channel 1 is inverted as well).

Channel Display: Displaying a math waveform automatically removes the display of channels used to create the math waveform.

Math Operations: Only one math operation is allowed.

Measure

Push the MEASURE button to access the automated measurement capabilities. There are five measurements available along with the ability to display up to four at a time. Following are the settings under the **Measure** menu, with either **Source** or **Type** highlighted.

Source

With the **Measure** menu displayed and **Source** highlighted, define the channel you want the measurement to be performed on.

<u>Menu</u>	<u>Settings</u>	<u>Comments</u>
Source		With Source highlighted, choose the channel to measure.
	CH1	Select a channel for the measurement.
	CH2	If the selected source (channel) is not displayed, CHx Off is displayed.

Type

With the **Measure** menu displayed and **Type** highlighted, define the menu structure by selecting the type of measurement to display in each of the available menu locations.

<u>Menu</u>	<u>Settings</u>	<u>Comments</u>
Type		With Type highlighted, choose the type of measurement to display next to the on-screen-menu button.
	Cyc RMS	Select the measurement type to display in each menu location.
	Mean	Cyc RMS: True RMS measurement of one complete cycle of the waveform.
	Period	Mean: Arithmetic mean voltage over the entire record.
	Pk-Pk	Period: Time for one cycle.
		Pk-Pk: Absolute difference between the maximum and minimum peaks of the entire waveform.
	Freq	Freq: Frequency of the waveform.
	None	None: To stop and remove measurements from the menu location.

Cursors

Push the CURSOR button to display the measurement cursors and cursor menu.

<u>Function</u>	<u>Settings</u>	<u>Comments</u>
	Voltage	Select and display the measurement cursors.
Type	Time	Voltage: Measures amplitude.
	Off	Time: Measures time and frequency.
	CH1	
Source	CH2	
	MATH	Choose the waveform of the channel or source that the cursors are attached.
	REFA	
	REFB	
Delta		The difference (delta) between the cursors is displayed here.
Cursor 1		Displays Cursor 1 location, (where time is a reference to the trigger position, and voltage is referenced to ground).
Cursor 2		Displays Cursor 2 location, (where time is a reference to the trigger position, and voltage is referenced to ground).

Acquire

Push the ACQUIRE button to set acquisition parameters.

<u>Function</u>	<u>Settings</u>	<u>Comments</u>
Sample		This is the default mode and provides the fastest acquisition.
Peak Detect		Use this to detect glitches and reduce the possibility of aliasing.
Average		Use this to reduce random or uncorrelated noise in the signal display. The number of averages is selectable.
Averages	4 16 64 128	Select the number of averages.

Note: If you probe a noisy square wave signal that contains intermittent, narrow glitches, the waveform displayed will vary depending on the acquisition mode you choose, as shown in Figure 14.

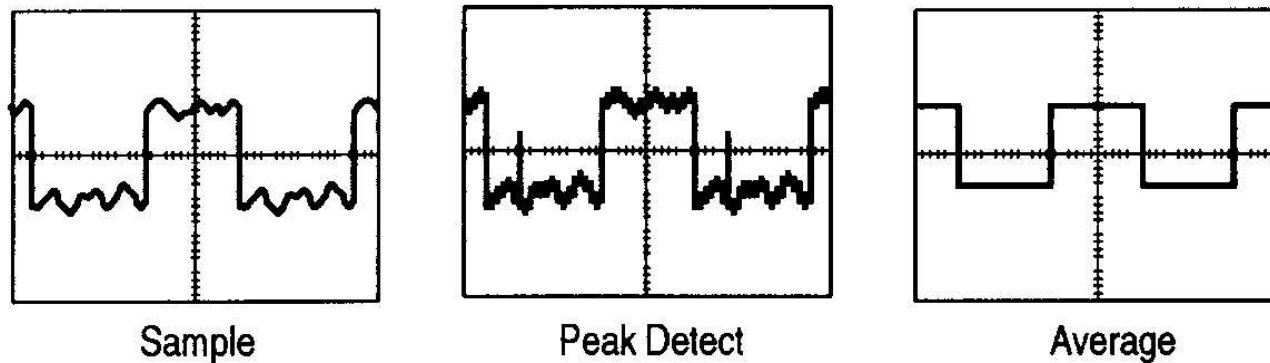















Figure 14: Display of a noisy signal depending on the acquisition mode

























APPENDIX E

Parts



Appendix E: Parts





This table has a list of parts:

Qty.	Description	Fig.	Supplier	Supplier #	Fig. A	Fig. B
1	Metal enclosure	A	Jameco	208928		
1	Transformer	B	Jameco	102111		
1	Power cord	C	Jameco	339733		
1	Fuse holder	D	Jameco	102867		
1	1A Fuse	E	Jameco	10372		
8	1N4004 Diode	F	Jameco	35991		
2	Capacitor	G	Jameco	331715		
1	HLMP1700 LED	H	Jameco	253690		
1	T1 LED mount	I	Jameco	95513		
1	4.7 kΩ 1/4W Resistor	J	Jameco	31026		
1	Heat shrink, 0.12" diameter	K	Jameco	184721		
1	Heat shrink, 0.16" diameter	K	Jameco	182730		
2	Machine screw, 10-24, 3/8"	L	McMaster-Carr	90272A240		

Qty.	Description	Fig.	Supplier	Supplier #	Fig. O	Fig. P
2	Nut, hex, 10-24	M	McMaster-Carr	90480A011		
1	TIP29 NPN Transistor	N	Jameco	297781		
10	2N4401 NPN Transistor	O	Jameco	38421		
2	1N5819 Schottkey Diode	F	Jameco	177965		
4	0.1μF ceramic	P	Mouser	581-SR205E104M		
3	100uF electric capacitor	Q	Jameco	93761		
5	1KΩ 1/4W Resistor	J	Jameco	29663		
2	2KΩ 1/4W Resistor	J	Jameco	30277		
2	0.68Ω 1W Resistor	J	Jameco	P0.68W-1BK-ND		
2	50K pot	R	Jameco	264428		
2	Heat sink	S	Mouser	532-507302B00		
2	3/8" 4-40 machine screw	L	McMaster-Carr	90272A108		
12	4-40 machine nut	M	McMaster-Carr	90480A005		
1	TIP30 PNP Transistor	N	Jameco	179346		

Appendix E: Parts

5	2N4403 PNP Transistor	O	Jameco	38447		
---	-----------------------	---	--------	-------	-------------------------------------------------------------------------------------	-------------------------------------------------------------------------------------

Qty.	Description	Fig.	Supplier	Supplier #	Fig. AC	Fig. AD
3	10K Ω 1/4W Resistor	J	Jameco	29911		
2	100K Ω 1/4W Resistor	J	Jameco	29997		
1	12VDC 2"x2" fan	T	Jameco	206965		
1	3 pin piece of male header	U	Jameco	103341		
2	LM741 Op Amp	V	Jameco	24539		
1	10K Ω Thermistor	W	Jameco	207036		
2	Machine screw, 1", 4-40	L	McMaster-Carr	90272A115		
10	100 Ω 1/4W Resistor	J	Jameco	29946		
2	2N7000 N-Channel MOSFET	O	Jameco	119423		
1	10 μ F electric capacitor	Q	Jameco	94369		
2.5	Circuit board, 3.75"x2"	Z	TekBots	protoboard.1		

1	On-Off Toggle switch	AA	Jameco	76523		
---	----------------------	----	--------	-------	--	--

Qty.	Description	Fig.	Supplier	Supplier #		
2	Binding Posts	A B	Jameco	71239		
1	Power Cord strain relief	A C	Jameco	182369		
1	CAT5 cable, 1 foot	A D	Jameco	201603		
1	22AWG stranded wire (5 ft), black	A E	Jameco	126084		
1	22AWG stranded wire (5 ft), red	A E	Jameco	126033		
8	Machine screw, 4-40, 1/2"	L	McMaster- Carr	90272A110		
8	Mounting spacer, 3/16" long	A F	McMaster- Carr	94639A704		
2	10Ω 1/4W Resistor	J	Jameco	93761		

APPENDIX F

Suppliers

Appendix F: Suppliers

This section has a list of our suppliers:

DigiKey	701 Brooks Ave. South Thief River Falls, MN 56701-0677 (800) 344-4539 http://www.digikey.com
Mouser Electronics	1000 N. Main Street, Mansfield, TX 76063 (800) 346-6873 http://www.mouser.com
Allied Electronics	6700 SW 105th St, Suite 106 Beaverton, OR 97008 (800) 433-5700 http://www.alliedelec.com
TekBots	220 Owen Hall Oregon State University Corvallis, OR 97331 tekbots_support@eecs.oregonstate.edu http://eecs.oregonstate.edu/tekbots
Solarbotics	179 Harvest Glen Way N.E. Calgary, Alberta, Canada T3K 4J4 (866) B-ROBOTS http://www.solarbotics.com
McMaster-Carr	P.O. Box 7690, Chicago, IL 60680-7684 (562) 692-5911 http://www.mcmaster.com
Jameco Electronics	1355 Shoreway Rd, Belmont, CA 94002 (800) 831-4242 http://www.jameco.com

