

Chapter 1

Cross Over Design

1.1 Pre-Lab

The answers to the following questions are due at the beginning of the lab. If they are not done at the beginning of the lab, no points will be awarded. Bring two copies as one will be turned into the teaching assistant.

1. No Pre-lab this time!

1.2 Section Overview

Most home and car audio systems contain multiple speakers such as a tweeter, mid-range and woofer. This is because each speaker has a specific range of frequencies it was designed to output. In fact, tweeters may break if powered with lower frequencies and woofers can not move fast enough to generate higher frequencies. To deal with this, speaker systems have crossovers. These crossovers are filters designed to prevent unwanted frequencies to each speaker. Crossovers are commonly designed to be either two-way or three-way based on the number of speakers, two and three speakers respectively. In this lab, each group will be designing and building a three way crossover network to drive a multiple speaker system. Speakers are provided, but these speakers too have optimal output frequencies. The following graph, figure 1.1, shows what the frequency response of a crossover network response might look like. Note that the solid lines are magnitude and the dashed lines are phase shifts.

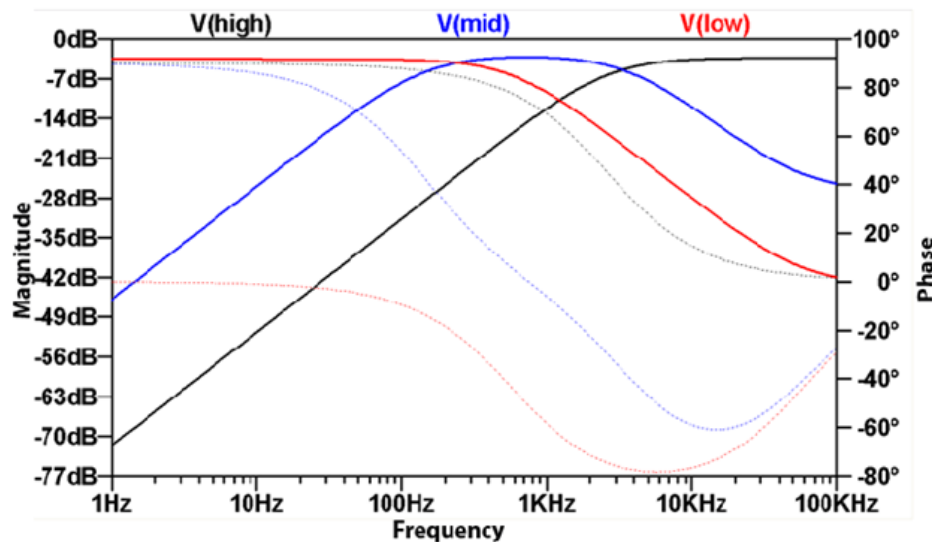

Figure 1.1: Three-way Crossover Frequency Responses

1.3 Procedure

The final product of this lab is a functional crossover network comprised of three filters and an amplifier for each filter. When creating crossovers, there are two methods of filtering the audio. The first is to filter after amplification, and the second is to filter before amplification. Some simple, low cost, and low quality systems will filter after amplification, but this wastes power and requires bulky components to work well. Most designs have the cross over first then amplify the signal for each speaker separately. This is the recommended design. A block diagram is shown in figure 1.2

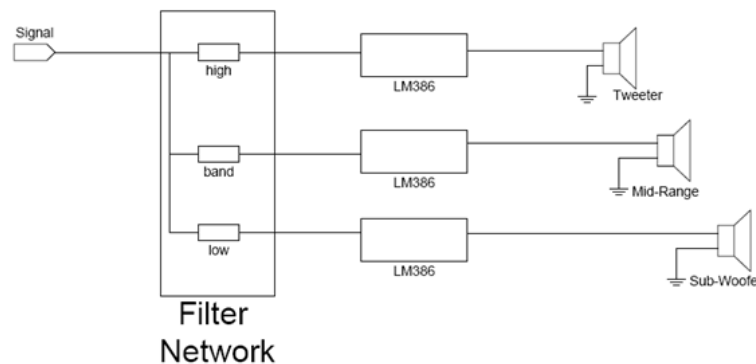

Figure 1.2: Block Diagram for Three-Way Crossover

The procedure for this lab can be broken up into three main steps as listed below.

1. Design a bandpass, low pass, and high pass filters with appropriate pass frequencies. The design will be simulated in LTspice using an AC analysis to ensure expected behavior.
2. Construct a physical prototype of each filter and test the filters over a range of frequencies using the frequency generator and o-scope.
3. Solder the working filters and amplifiers onto a protoboard and prepare for final testing. A schematic for the amplifier will be provided.

At the end of this lab, each group will perform a final test of their speakers and crossover using a frequency sweep, such as the *Ultimate Sound Test* on YouTube. Grading will be based on how well each filter passes the expected frequencies and stops all others.

1.4 Design and Simulation

The first step in the design phase for this lab is to decide on appropriate pass and stop frequencies for each filter. The tweeter speaker can produce frequencies greater than 5Khz, and the sub box can produce frequencies less than 200Hz. For proper sound, the midrange should produce all frequencies not produced by the subwoofer or tweeter. To verify that the mid-range can produce these frequencies, refer to the datasheet for the midrange on the webpage.

The final implementation of the design will be driven by an audio jack on a computer. In order for this to be successful the filter can not be designed so that it 'overloads' the audio jack. If this was to happen, no sound would come from the computer and it could even be damaged. When designing the system assume that the audio jack on the computer cannot source more than 10mA of current. As a rule of thumb, avoid using any resistors less than 100 Ohms.

Based on the frequencies that should be filtered, create filters similar to those from Lab 5. The corner frequencies will need to be modified, which can be done by changing component values. It is recommended that the values for the inductors be selected first from the possible values included in the lab kits (1mH and 10mH) as it is easier to find capacitors than it is to find inductors. Starting from those values, design the filters. Pay attention to the output voltages of your filters. The input will typically be at most 1 Vpp and the amplifiers included in your kits have a fixed gain of 20. You will be supplying the amplifiers with 12 volts. This means to be safe that the maximum output from your filters can be about 0.6 Vpp. If your output voltage is too great, you can simply turn down the volume.

HINT: To best design the filter, the output impedance is also needed. This can be found on the datasheet for the LM386 part. Be sure to account for it.

CHAPTER 1. CROSS OVER DESIGN

To simulate the filters, use an *AC Analysis* in LTspice. To perform an AC analysis, draw the circuit and set the voltage source to a DC value of **AC 1**. Under **Simulate**, choose **Edit Simulation Cmd** and select the **AC Analysis tab**. Choose **Decade** for the type of sweep, **100** points per decade, a start frequency of **10Hz**, and a stop frequency of **100Khz**. Running the simulation will now give a graph of output voltage relative to input voltage on a log scale over the selected range of frequencies. Note: the solid line is the magnitude response, and the dashed line is the phase shift.

1.5 Prototype and Test

Once the filters are designed and verified, construct the filters on a breadboard and test the response over a range of frequencies. Use the frequency generator and oscilloscope to fill in the table 1.1 below.

Table 1.1: Crossover Measurements

Freq (Hz)	VIN	VOUT Low	VOUT Mid.	VOUT High
10Hz				
30Hz				
100Hz				
300Hz				
1KHz				
3KHz				
10KHz				
30KHz				

1.6 Construction and Final Testing

The final step is to solder the circuit onto a protoboard. Solder the filters to one side of the board, conserving as much space for amplifier as possible. For soldering the amplifier, refer to the demo board and the schematic provided. Be sure to connect wires to the filter input, output, and the amplifier output for testing and verification.

Table 1.2: Final Testing

Filter	Pass Bands Acceptable?	Stop Bands Acceptable?
Low Pass		
High Pass		
Band Pass		

1.7 Study Questions

Turn in a well written report including all schematics, calculations, and simulation results. Be sure to describe how you determined the component values for each filter.