

## ENGR 202 Lab 4 Investigation

An ENGR 202 student has just soldered together a reactive and resistive component, and neatly placed them inside of a box and glued it shut with Acme titanium strength superglue (which cannot be broken even by the heaviest of sledge hammers). But the student forgot which components they put in the box! It is up to you to figure out what the components are. The student says there are two components in the box are connected in series: one component is a resistor, and the other is either an inductor or capacitor.

To figure out what components are in the box, you have ingeniously constructed the following circuit. The signal generator is set to a 5V amplitude (0-pk) sinusoidal waveform at 4000Hz.

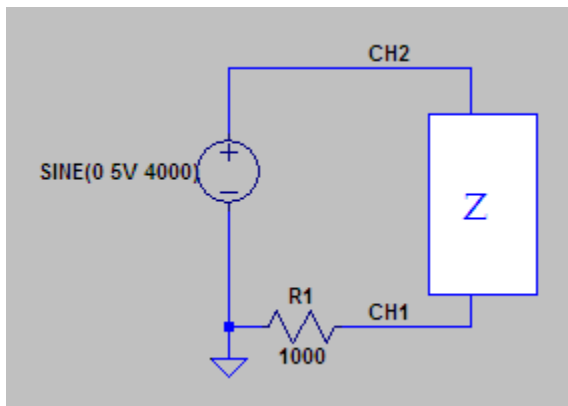

An oscilloscope connected to nodes CH2 and CH1 gave the waveforms shown below. The green waveform is Channel 2, the blue waveform is Channel 1, and the red waveform is zero.

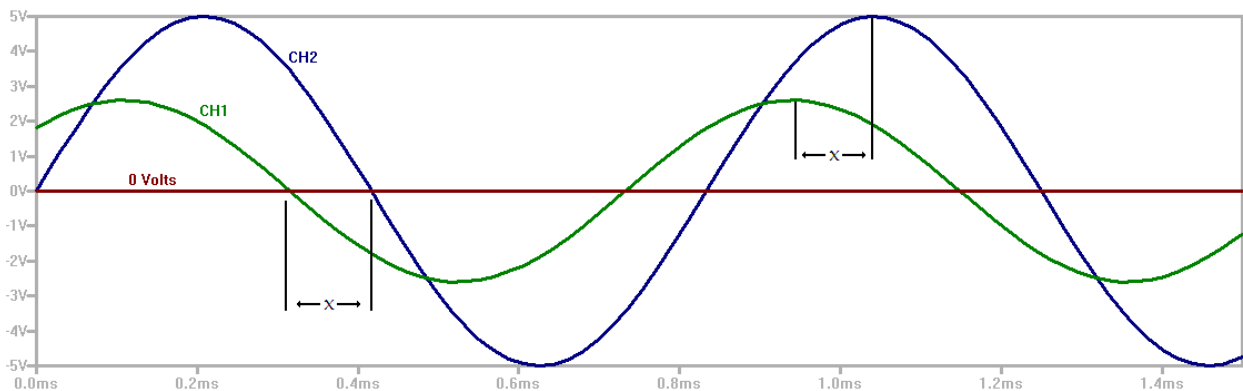

From careful measurements, you have determined that the time difference between the rising edge zero-crossings (which is the same as the difference in peaks) is  $x = 101.06\mu\text{s}$ . The CH2 voltage is measured at **10V peak to peak**, and the CH1 voltage is **5.205V peak to peak**. With this information, you now have all you need to know to figure out exactly what is in the box.

Lab 4 Investigation Questions:

NAME: \_\_\_\_\_

1. Express the CH2 voltage as a phasor (Amplitude at some angle) with a zero degree phase shift.

\_\_\_\_\_

2. Using CH2 as a reference, what is the phase shift in degrees of CH1?

\_\_\_\_\_ degrees

3. Express the voltage CH1 as a phasor.

\_\_\_\_\_

4. What is the current through resistor R1? Express the answer as a phasor.

\_\_\_\_\_

5. What is the current through the entire circuit? **a)** same as answer 4 above, or **b)** something else

6. What is in the box? **a)** Resistor and Capacitor **b)** Resistor and Inductor

7. What is the total impedance of the circuit  $Z_{total} = R1 + Z$ ? Express as an actual number in terms of a real part and imaginary part. Hint:  $Z = V/I$

$Z_{total} =$  \_\_\_\_\_ ( + - ) \_\_\_\_\_ (j)

8. What is the impedance of just  $Z$  by itself?

$Z =$  \_\_\_\_\_ ( + - ) \_\_\_\_\_ (j)

9. What is the value of the resistive component in the box? Express the answer in Ohms.

\_\_\_\_\_ [Ohms]

10. What is the value of the reactive component? Recall the frequency is  $f = 4000\text{Hz}$ . Express the answer in Henrys or Farads.

\_\_\_\_\_ [ ]