

Calculating Power Dissipation

The passive sign convention

When we observe that positive current enters the positive terminal of a component, we say that the component obeys the *passive sign convention* (PSC). Therefore, when the passive sign convention is being obeyed, it indicates that a component is dissipating energy (or power) as charge is being displaced from a higher potential to a lower potential.

One way to think about this is using another water analogy. If we splice a piece of garden hose into a length of firehose, we create a pressure potential. The high pressure side is the one where the water is entering. The garden hose is analogous to a resistor which impedes the flow of current. Thus, when current flows through a resistor, a higher voltage potential will exist on the incoming current side. In this example, the garden hose and the resistor are obeying the passive sign convention.

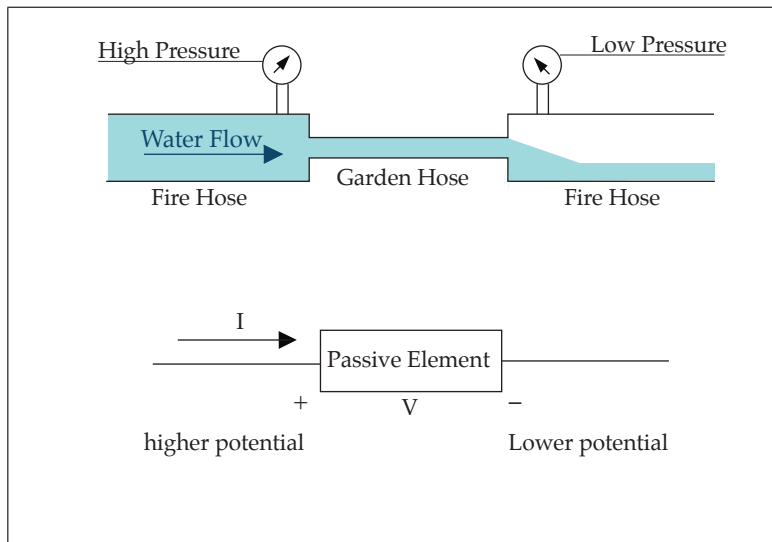

Figure 1: A Restriction Causes Higher Pressure on One Side

To reiterate, the PSC is obeyed when the current enters an element's positive terminal and exits at the negative terminal.

The passive sign convention is usually used for assigning reference marks for voltage drops across, and currents through, resistors, but we frequently assign a current and associated direction for a current through a voltage source in violation of the PSC. By the same token, we frequently define a voltage and its associated reference marks across a current source in violation of the PSC.

The use of the word violation does not indicate that something is wrong or incorrect, but that the element in question is not obeying the *passive* sign convention. In other words, it's not behaving as a passive component dissipating power but as an *active* device supplying power.

Power Dissipation

We say a component is *dissipating* or absorbing power when it is causing a loss in electrical potential of the charge carriers going through it. An ideal example is where current traveling through a resistor causes a voltage drop to occur across its terminals. The voltage drop is indicative of a loss in energy, as voltage is the change in potential energy as charge is moved between two points. Where did this energy go? For passive elements, the electrical energy was converted to heat. The same mechanism occurs in a electrical space heater, just to a substantial degree.

We say a component is generating or delivering power when it is converting some type of energy into electrical energy. An example would be a battery whose operation converts stored chemical energy into electrical energy.

Some components such as a battery can depending on circumstances, either dissipate or generate power. A battery generates power when it powers a light bulb. It dissipates power when it is being charged. The charging process converts applied current into stored chemical energy. and the process generates heat.

You can determine the power dissipation of a device by observing the current direction and magnitude and voltage magnitude and polarity at its terminals. To calculate power *dissipation* (not generation!), you orient the current reference arrow at the component so that it points towards the positive terminal. (i.e., the assumption is that the PSC is obeyed). See figure 2.

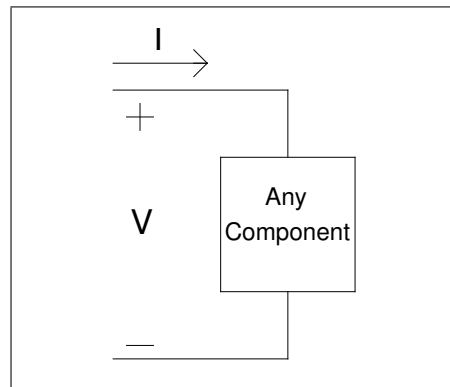

Figure 2: Orientation of V and I for Computing Power

To orient the arrow as such it may be necessary to adjust the sign of the magnitude of the current. It is sometimes easier to reorient the voltage reference terminals so that the current arrow is pointing into the positive terminals. In any case, to set up the problem for solving for power dissipated, you adjust the current arrow and/or the voltage references so that the arrow points towards the positively marked terminal.

Since the VI product represents the power dissipated, *positive power dissipation is power removed (dissipated as heat) from the electrical domain*. Assuming that the voltage and current are defined as discussed above we can determine the sign of the power dissipation from the signs of I and V . Hence we can determine whether a component is dissipating power or generating power simply

by knowing the quadrant in which it is operating on its I-V plot as shown below.

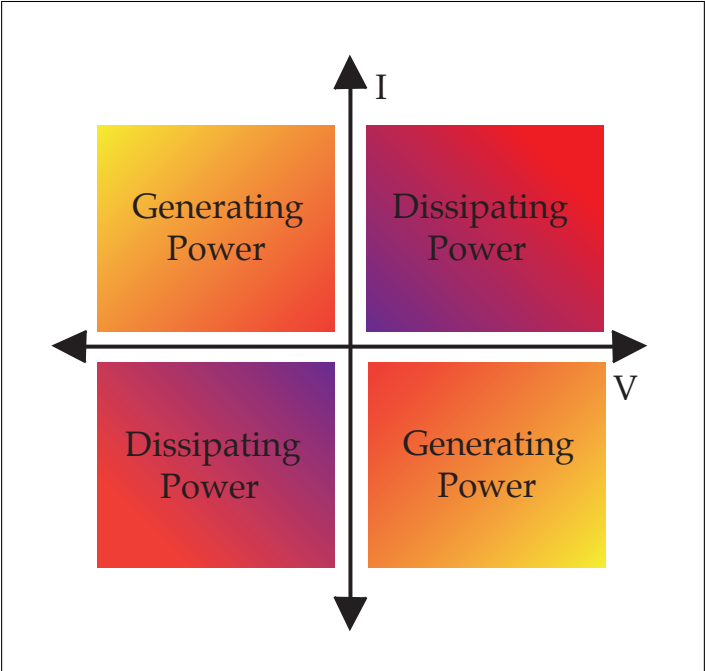

Figure 3: Each quadrant indicates power dissipation or generation