

Features

- Optimized for high-performance 3.3V systems
 - 5 ns pin-to-pin logic delays, with internal system frequency up to 208 MHz
 - Small footprint packages including VQFPs, TQFPs and CSPs (Chip Scale Package)
 - Pb-free available for all packages
 - Lower power operation
 - 5V tolerant I/O pins accept 5V, 3.3V, and 2.5V signals
 - 3.3V or 2.5V output capability
 - Advanced 0.35 micron feature size CMOS FastFLASH technology
- Advanced system features
 - In-system programmable
 - Superior pin-locking and routability with FastCONNECT II™ switch matrix
 - Extra wide 54-input Function Blocks
 - Up to 90 product-terms per macrocell with individual product-term allocation
- Local clock inversion with three global and one product-term clocks
- Individual output enable per output pin with local inversion
- Input hysteresis on all user and boundary-scan pin inputs
- Bus-hold circuitry on all user pin inputs
- Supports hot-plugging capability
- Full IEEE Standard 1149.1 boundary-scan (JTAG) support on all devices
- Four pin-compatible device densities
 - 36 to 288 macrocells, with 800 to 6400 usable gates
- Fast concurrent programming
- Slew rate control on individual outputs
- Enhanced data security features
- Excellent quality and reliability
 - 10,000 program/erase cycles endurance rating
 - 20 year data retention
- Pin-compatible with 5V core XC9500 family in common package footprints

Table 1: XC9500XL Device Family

	XC9536XL	XC9572XL	XC95144XL	XC95288XL
Macrocells	36	72	144	288
Usable Gates	800	1,600	3,200	6,400
Registers	36	72	144	288
T _{PD} (ns)	5	5	5	6
T _{SU} (ns)	3.7	3.7	3.7	4.0
T _{CO} (ns)	3.5	3.5	3.5	3.8
f _{SYSTEM} (MHz)	178	178	178	208

Table 2: XC9500XL Packages and User I/O Pins (not including 4 dedicated JTAG pins)

Package ⁽¹⁾	XC9536XL	XC9572XL	XC95144XL	XC95288XL
PC44	34	34	-	-
PCG44	34	34		
VQ44	34	34	-	-
VQG44	34	34		
CS48	36	38	-	-
CSG48	36	38		
VQ64	36	52	-	-
VQG64	36	52		
TQ100	-	72	81	-
TQG100		72	81	
CS144	-	-	117	-
CSG144			117	
TQ144	-	-	117	117
TQG144			117	117
PQ208	-	-	-	168
PQG208				168
BG256	-	-	-	192
BGG256				192
FG256	-	-	-	192
FGG256				192
CS280	-	-	-	192
CSG280				192

Notes:

(1) The letter "G" as the third character indicates a Pb-free package.

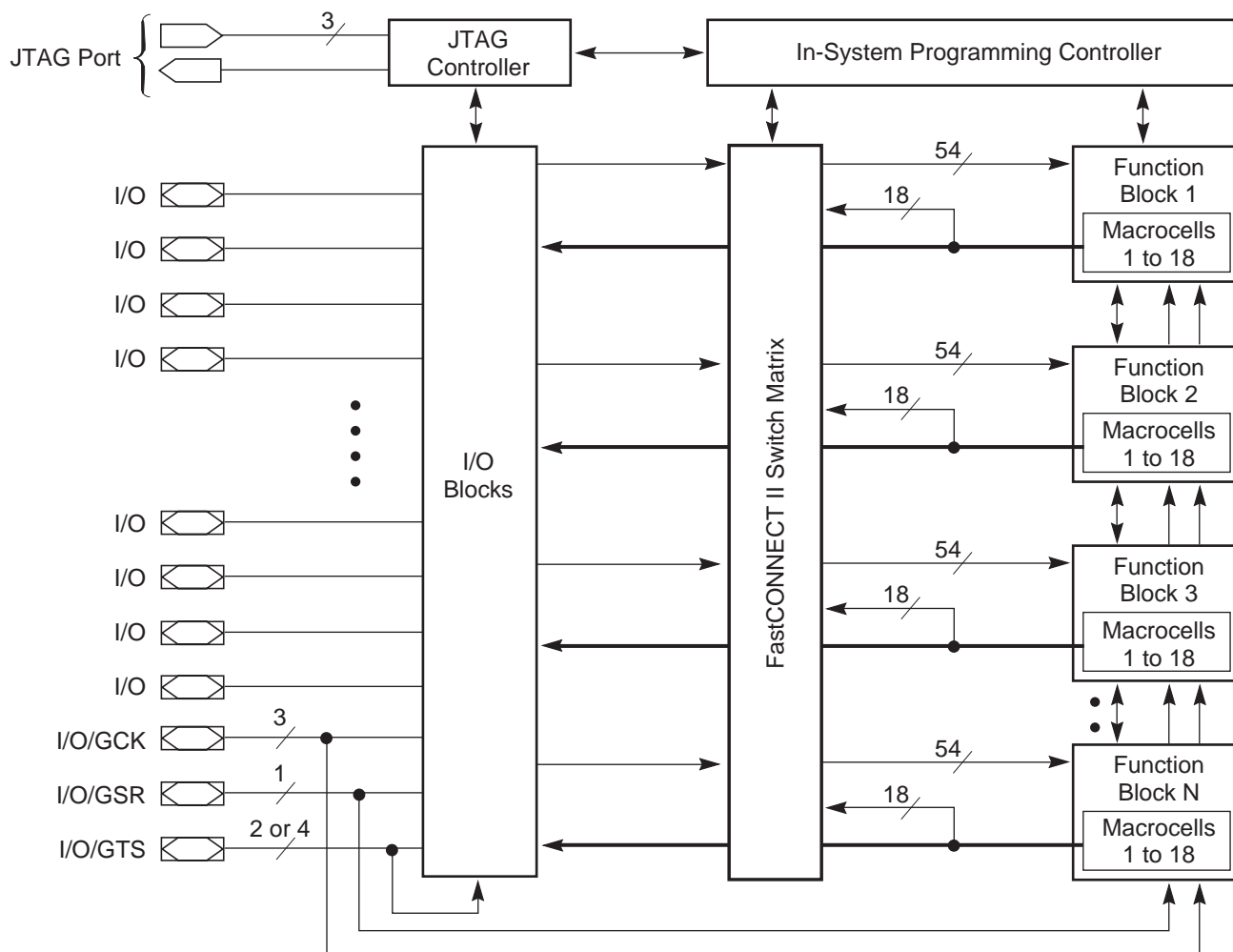

DS054_01_042001

Figure 1: XC9500XL Architecture

Note: Function block outputs (indicated by the bold lines) drive the I/O blocks directly.

Family Overview

The FastFLASH XC9500XL family is a 3.3V CPLD family targeted for high-performance, low-voltage applications in leading-edge communications and computing systems, where high device reliability and low power dissipation is important. Each XC9500XL device supports in-system programming (ISP) and the full IEEE 1149.1 (JTAG) boundary-scan, allowing superior debug and design iteration capability for small form-factor packages. The XC9500XL family is designed to work closely with the Xilinx Virtex, Spartan-XL and XC4000XL FPGA families, allowing system designers to partition logic optimally between fast interface circuitry and high-density general purpose logic. As shown in Table 1, logic density of the XC9500XL devices ranges from 800 to 6400 usable gates with 36 to 288 registers, respectively. Multiple package options and associated I/O

capacity are shown in Table 2. The XC9500XL family members are fully pin-compatible, allowing easy design migration across multiple density options in a given package footprint.

The XC9500XL architectural features address the requirements of in-system programmability. Enhanced pin-locking capability avoids costly board rework. In-system programming throughout the full commercial operating range and a high programming endurance rating provide worry-free reconfigurations of system field upgrades. Extended data retention supports longer and more reliable system operating life.

Advanced system features include output slew rate control and user-programmable ground pins to help reduce system noise. Each user pin is compatible with 5V, 3.3V, and 2.5V inputs, and the outputs may be configured for 3.3V or 2.5V

operation. The XC9500XL device exhibits symmetric full 3.3V output voltage swing to allow balanced rise and fall times. Additional details can be found in the application notes listed in "Further Reading" on page 17.

Architecture Description

Each XC9500XL device is a subsystem consisting of multiple Function Blocks (FBs) and I/O Blocks (IOBs) fully interconnected by the FastCONNECT II switch matrix. The IOB provides buffering for device inputs and outputs. Each FB provides programmable logic capability with extra wide 54 inputs and 18 outputs. The FastCONNECT II switch matrix connects all FB outputs and input signals to the FB inputs. For each FB, up to 18 outputs (depending on package pin-count) and associated output enable signals drive directly to the IOBs. See Figure 1

Function Block

Each Function Block, as shown in Figure 2 is comprised of 18 independent macrocells, each capable of implementing a combinatorial or registered function. The FB also receives global clock, output enable, and set/reset signals. The FB generates 18 outputs that drive the FastCONNECT switch matrix. These 18 outputs and their corresponding output enable signals also drive the IOB.

Logic within the FB is implemented using a sum-of-products representation. Fifty-four inputs provide 108 true and complement signals into the programmable AND-array to form 90 product terms. Any number of these product terms, up to the 90 available, can be allocated to each macrocell by the product term allocator.

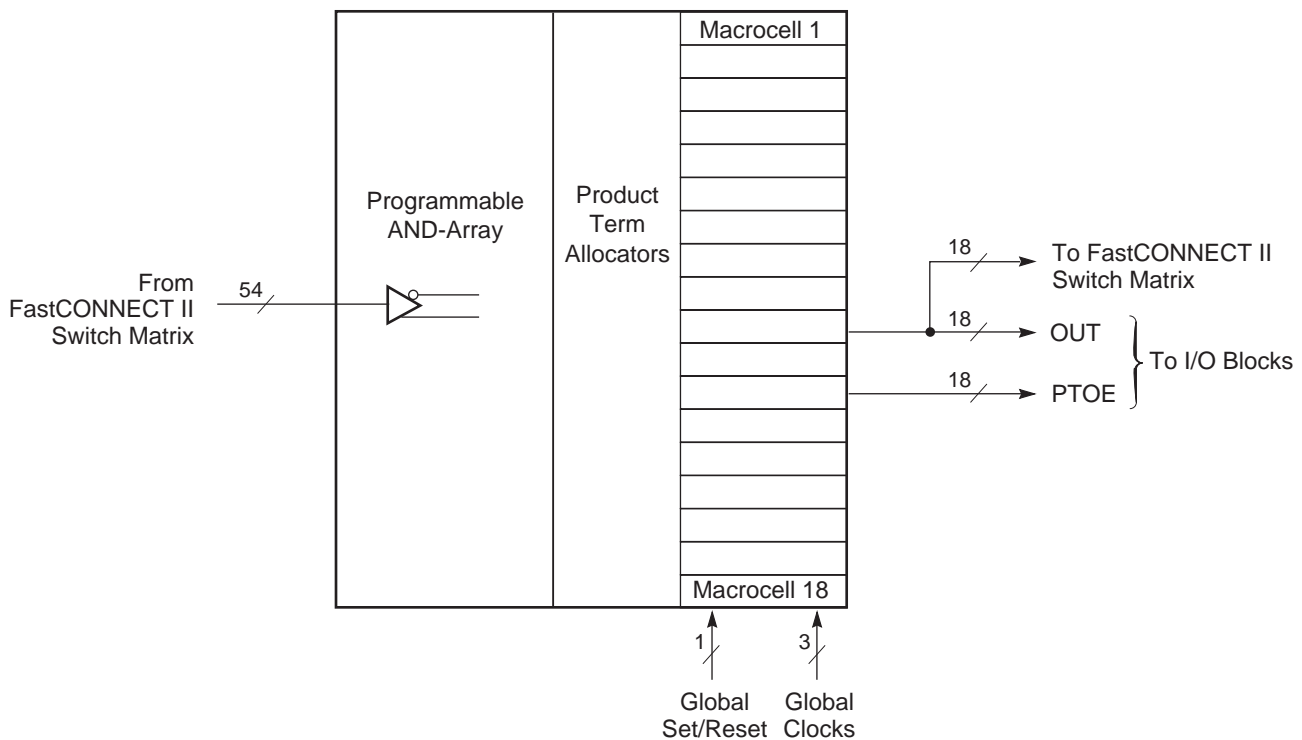

DS054_02_042101

Figure 2: XC9500XL Function Block

Macrocell

Each XC9500XL macrocell may be individually configured for a combinatorial or registered function. The macrocell and associated FB logic is shown in Figure 3.

Five direct product terms from the AND-array are available for use as primary data inputs (to the OR and XOR gates) to implement combinatorial functions, or as control inputs

including clock, clock enable, set/reset, and output enable. The product term allocator associated with each macrocell selects how the five direct terms are used.

The macrocell register can be configured as a D-type or T-type flip-flop, or it may be bypassed for combinatorial operation. Each register supports both asynchronous set and reset operations. During power-up, all user registers

are initialized to the user-defined preload state (default to 0 if unspecified).

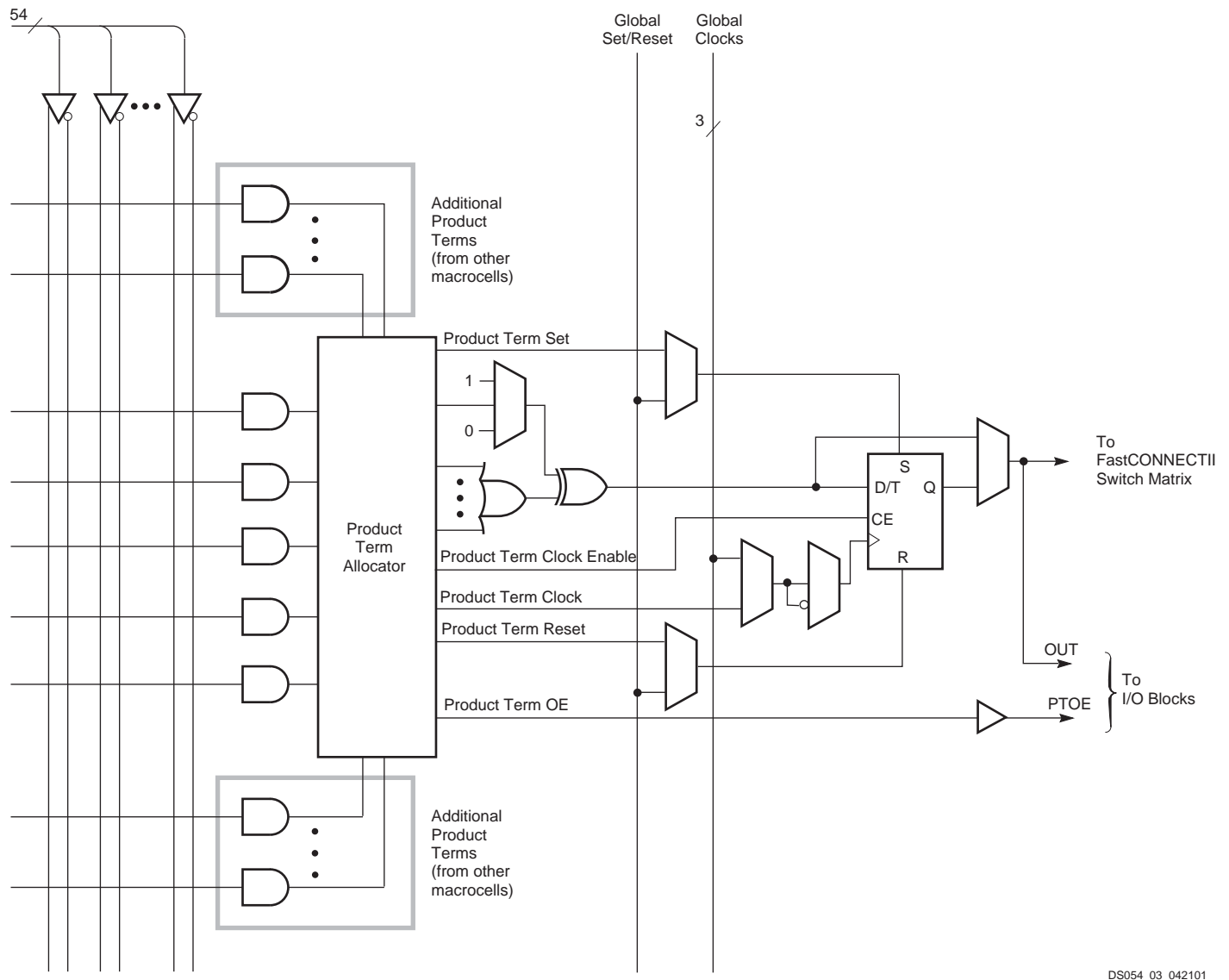
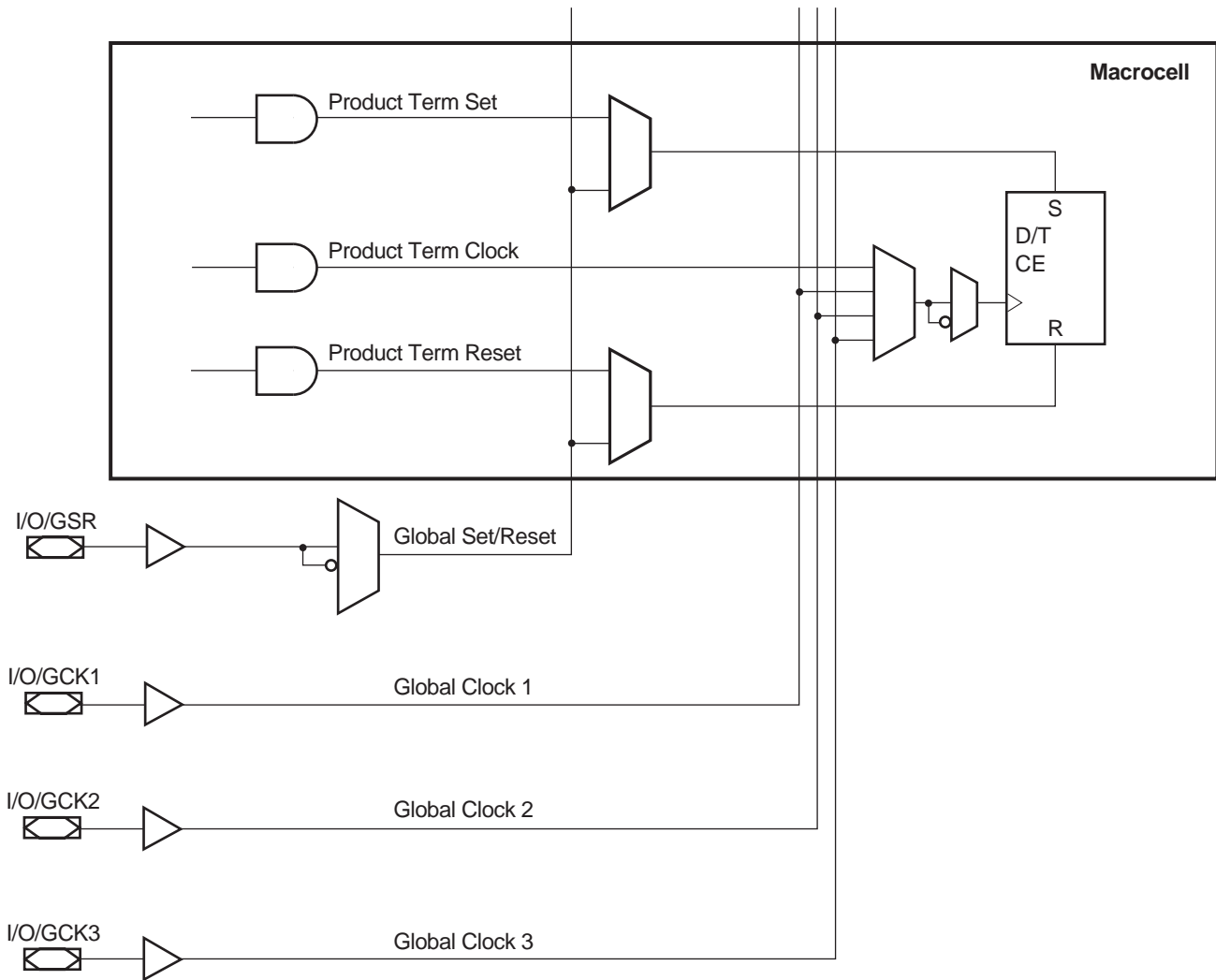

Figure 3: XC9500XL Macrocell Within Function Block

All global control signals are available to each individual macrocell, including clock, set/reset, and output enable signals. As shown in Figure 4, the macrocell register originates from either of three global clocks or a product

term clock. Both true and complement polarities of the selected clock source can be used within each macrocell. A GSR input is also provided to allow user registers to be set to a user-defined state.



DS05404_042101

Figure 4: Macrocell Clock and Set/Reset Capability

Product Term Allocator

The product term allocator controls how the five direct product terms are assigned to each macrocell. For example, all five direct terms can drive the OR function as shown in Figure 5.

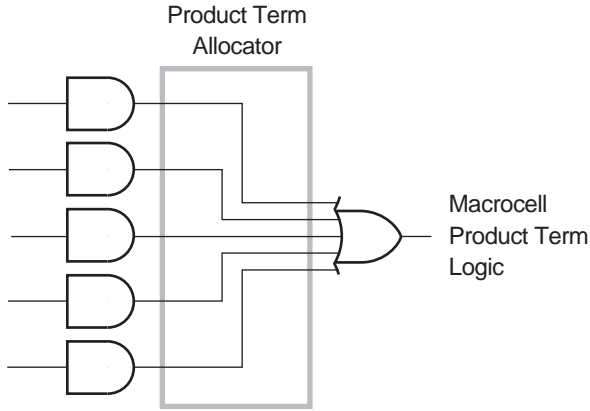

DS054_05_042101

Figure 5: Macrocell Logic Using Direct Product Term

The product term allocator can re-assign other product terms within the FB to increase the logic capacity of a macrocell beyond five direct terms. Any macrocell requiring additional product terms can access uncommitted product terms in other macrocells within the FB. Up to 15 product terms can be available to a single macrocell with only a small incremental delay of t_{PTA} , as shown in Figure 6.

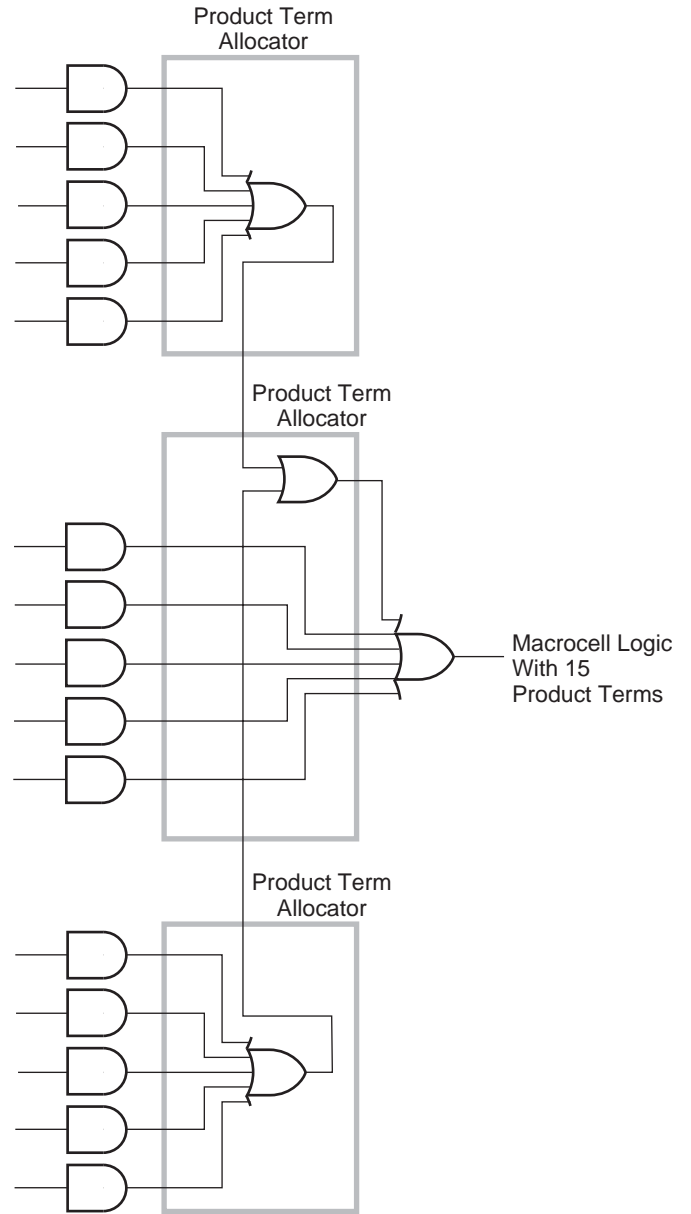

DS054_06_042101

Figure 6: Product Term Allocation With 15 Product Terms

The product term allocator can re-assign product terms from any macrocell within the FB by combining partial sums of products over several macrocells, as shown in **Figure 7**. In this example, the incremental delay is only $2 \cdot T_{PTA}$. All 90 product terms are available to any macrocell, with a maximum incremental delay of $8 \cdot T_{PTA}$.

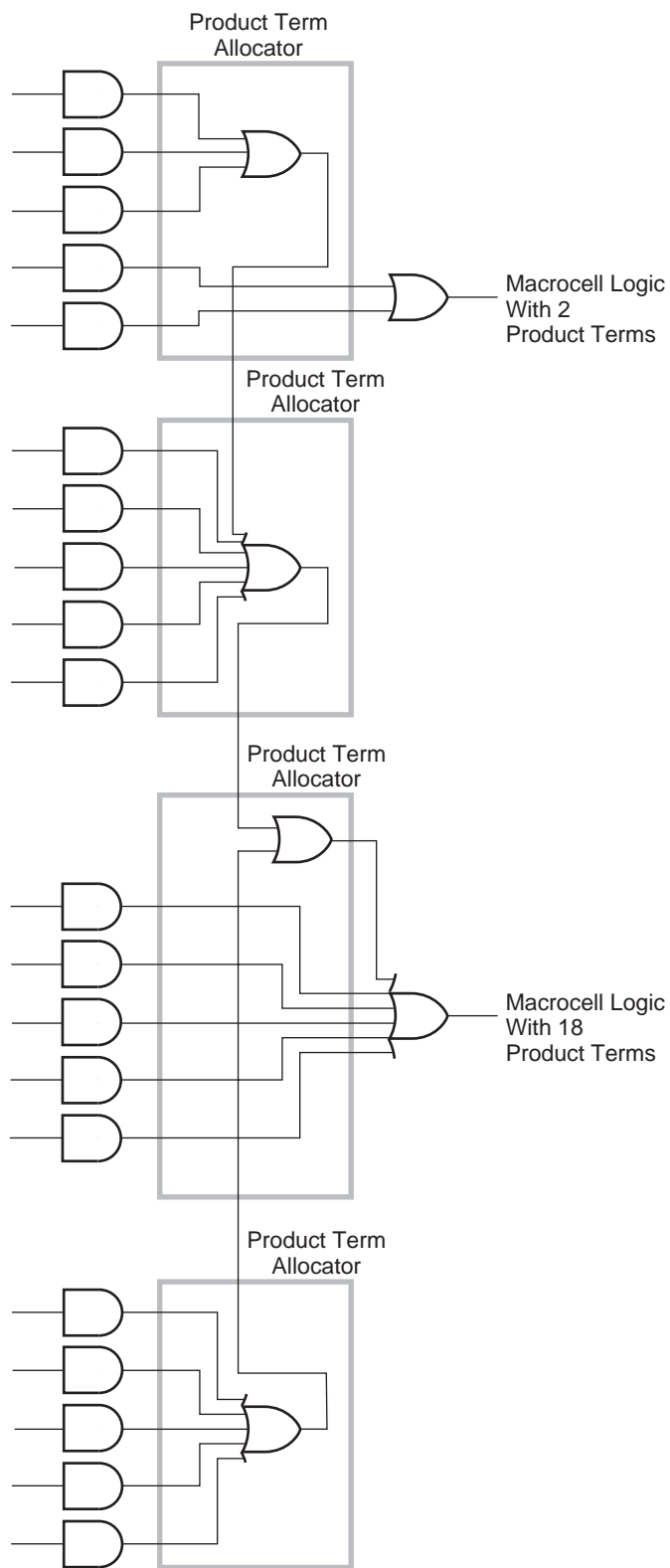

DS054_07_042101

Figure 7: Product Term Allocation Over Several Macrocells

FastCONNECT II Switch Matrix

The FastCONNECT II Switch Matrix connects signals to the FB inputs, as shown in Figure 9. All IOB outputs (corre-

sponding to user pin inputs) and all FB outputs drive the FastCONNECT II matrix. Any of these (up to a fan-in limit of 54) may be selected to drive each FB with a uniform delay.

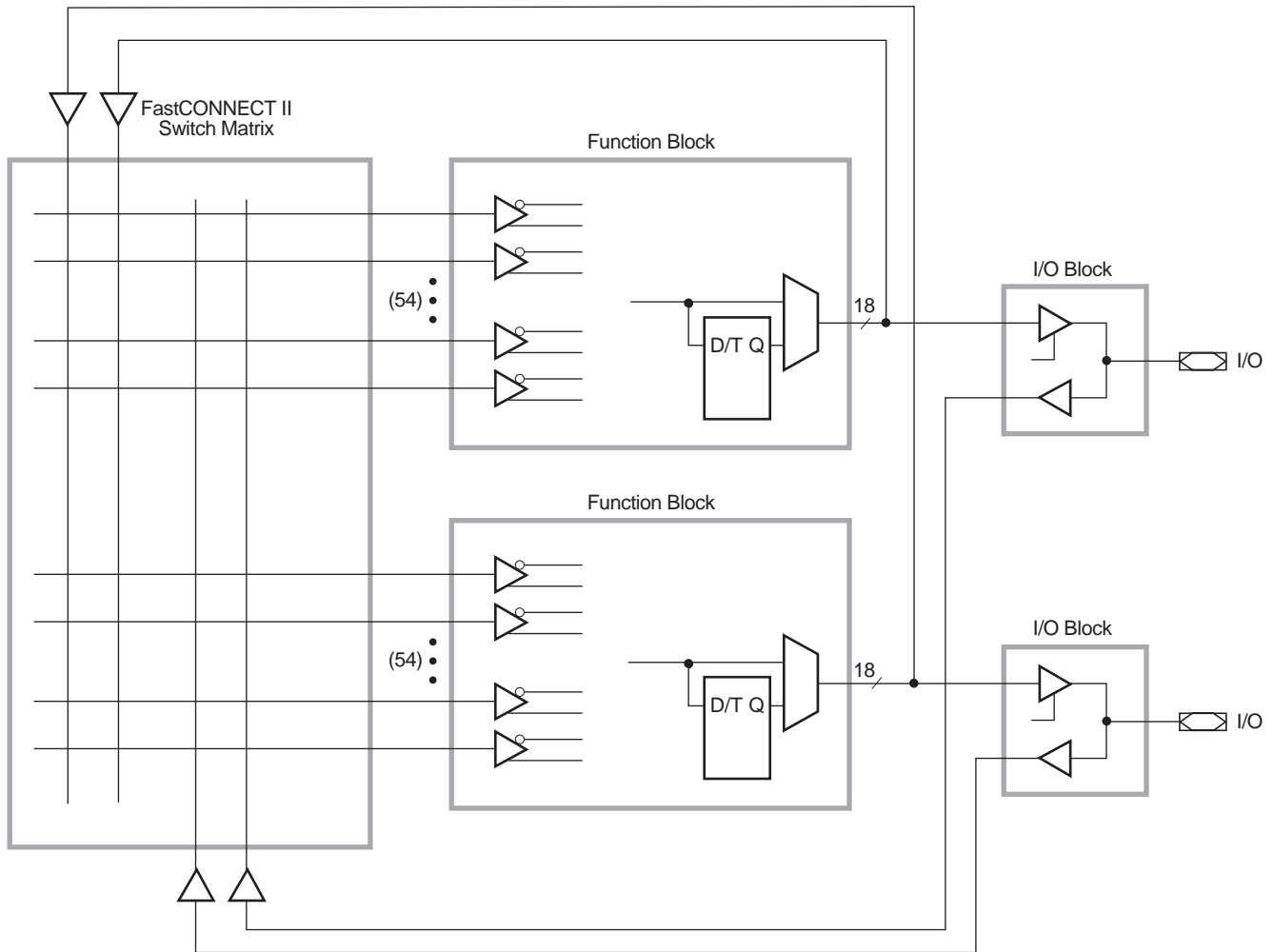

DS054_09_042101

Figure 9: FastCONNECT II Switch Matrix

I/O Block

The I/O Block (IOB) interfaces between the internal logic and the device user I/O pins. Each IOB includes an input

buffer, output driver, output enable selection multiplexer, and user programmable ground control. See Figure 10 for details.

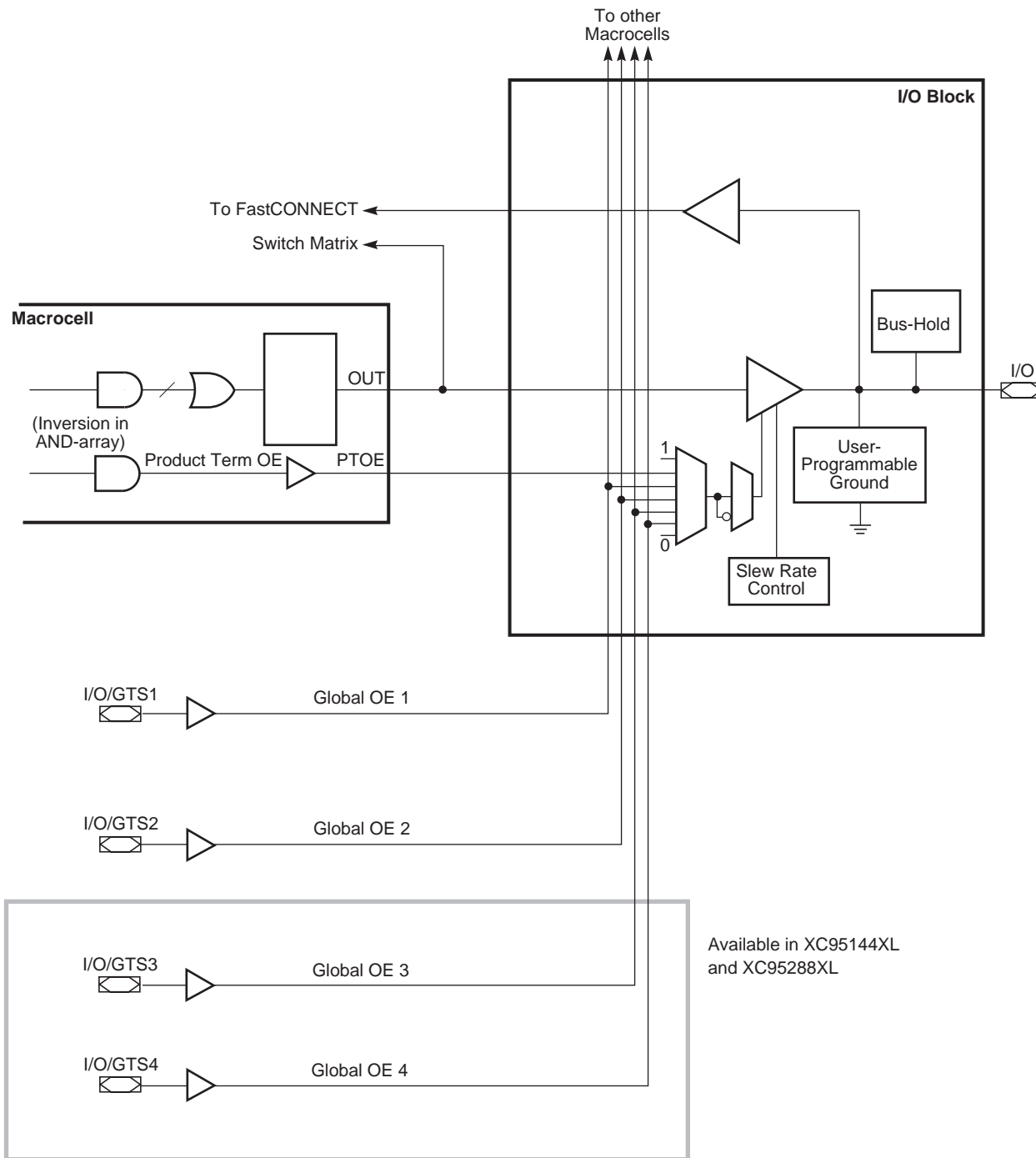

Figure 10: I/O Block and Output Enable Capability

The input buffer is compatible with 5V CMOS, 5V TTL, 3.3V CMOS, and 2.5V CMOS signals. The input buffer uses the internal 3.3V voltage supply (V_{CCINT}) to ensure that the input thresholds are constant and do not vary with the V_{CCIO} voltage. Each input buffer provides input hysteresis (50 mV

typical) to help reduce system noise for input signals with slow rise or fall edges.

Each output driver is designed to provide fast switching with minimal power noise. All output drivers in the device may be

configured for driving either 3.3V CMOS levels (which are compatible with 5V TTL levels as well) or 2.5V CMOS levels by connecting the device output voltage supply (V_{CCIO}) to a 3.3V or 2.5V voltage supply. **Figure 11** shows how the XC9500XL device can be used in 3.3V only systems and mixed voltage systems with any combination of 5V, 3.3V and 2.5V power supplies.

Each output driver can also be configured for slew-rate limited operation. Output edge rates may be slowed down to reduce system noise (with an additional time delay of t_{SLEW}) under user control. See **Figure 12**.

The output enable may be generated from one of four options: a product term signal from the macrocell, any of the global output enable signals (GTS), always “1,” or always “0.” There are two global output enables for devices with 72 or fewer macrocells, and four global output enables for devices with 144 or more macrocells. Any selected output enable signal may be inverted locally at each pin output to provide maximal design flexibility.

Each IOB provides user programmable ground pin capability. This allows device I/O pins to be configured as additional ground pins in order to force otherwise unused pins to a low voltage state, as well as provide for additional device

grounding capability. This grounding of the pin is achieved by internal logic that forces a logic low output regardless of the internal macrocell signal, so the internal macrocell logic is unaffected by the programmable ground pin capability.

Each IOB also provides for bus-hold circuitry (also called a “keeper”) that is active during valid user operation. The bus-hold feature eliminates the need to tie unused pins either high or low by holding the last known state of the input until the next input signal is present. The bus-hold circuit drives back the same state via a nominal resistance (R_{BH}) of 50k ohms. See **Figure 13**. Note the bus-hold output will drive no higher than V_{CCIO} to prevent overdriving signals when interfacing to 2.5V components.

When the device is not in valid user operation, the bus-hold circuit defaults to an equivalent 50k ohm pull-up resistor in order to provide a known repeatable device state. This occurs when the device is in the erased state, in programming mode, in JTAG INTEST mode, or during initial power-up. A pull-down resistor (1k ohm) may be externally added to any pin to override the default R_{BH} resistance to force a low state during power-up or any of these other modes.

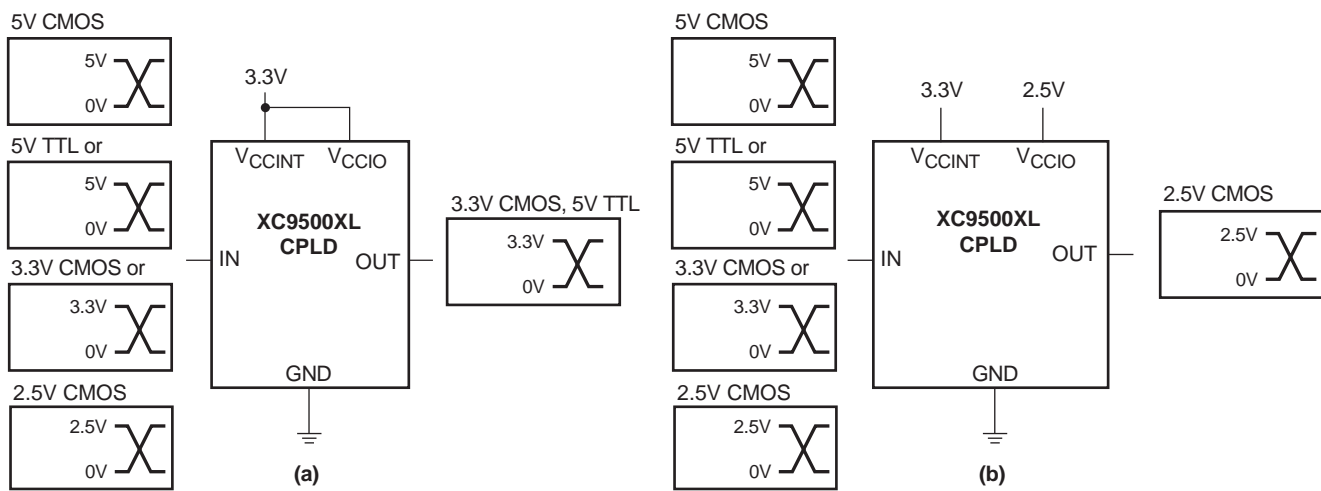

DS054_11_042101

Figure 11: XC9500XL Devices in (a) 3.3V only and (b) Mixed 5V/3.3V/2.5V Systems

5V Tolerant I/Os

The I/Os on each XC9500XL device are fully 5V tolerant even though the core power supply is 3.3 volts. This allows 5V CMOS signals to connect directly to the XC9500XL inputs without damage. In addition, the 3.3V V_{CCINT} power supply can be applied before or after 5V signals are applied to the I/Os. In mixed 5V/3.3V/2.5V systems, the user pins, the core power supply (V_{CCINT}), and the output power supply (V_{CCIO}) may have power applied in any order. This makes the XC9500XL devices immune to power supply sequencing problems.

Xilinx proprietary ESD circuitry and high impedance initial state permit hot plugging cards using these devices.

Pin-Locking Capability

The capability to lock the user defined pin assignments during design iteration depends on the ability of the architecture to adapt to unexpected changes. The XC9500XL devices incorporate architectural features that enhance the ability to accept design changes while maintaining the same pinout.

The XC9500XL architecture provides for superior pin-locking characteristics with a combination of large number of routing switches in the FastCONNECT II switch matrix, a 54-wide input Function Block, and flexible, bi-directional product term allocation within each macrocell. These features address design changes that require adding or changing internal routing, including additional signals into existing equations, or increasing equation complexity, respectively.

For extensive design changes requiring higher logic capacity than is available in the initially chosen device, the new design may be able to fit into a larger pin-compatible device using the same pin assignments. The same board may be used with a higher density device without the expense of board rework.

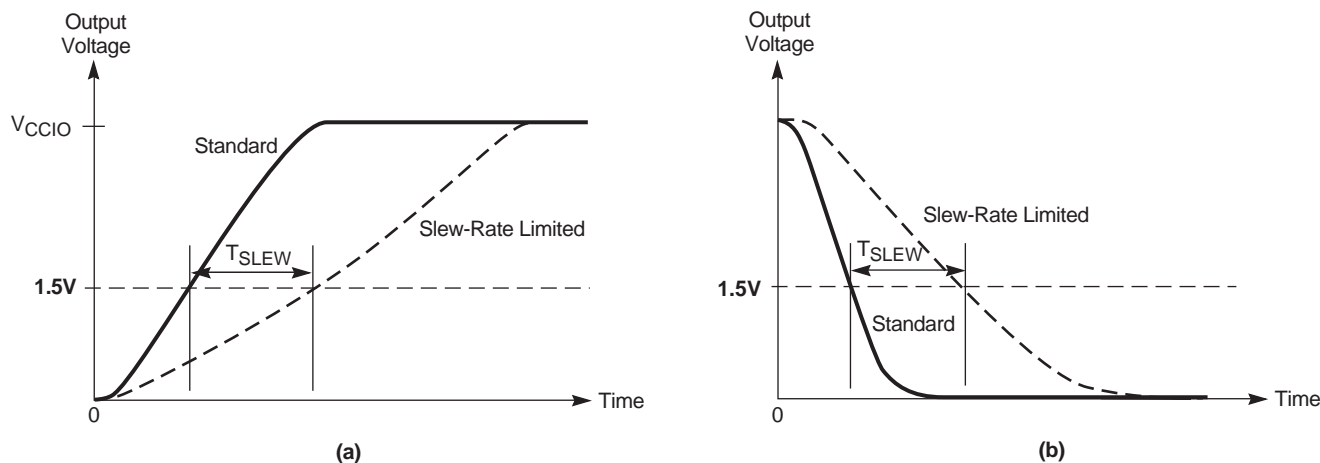

DS054_12_042101

Figure 12: Output Slew-Rate Control For (a) Rising and (b) Falling Outputs

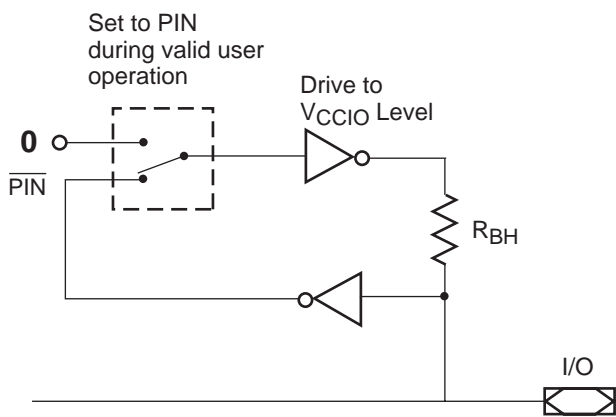

DS054_13_042101

Figure 13: Bus-Hold Logic

In-System Programming

One or more XC9500XL devices can be daisy chained together and programmed in-system via a standard 4-pin JTAG protocol, as shown in Figure 14. In-system programming offers quick and efficient design iterations and eliminates package handling. The Xilinx development system provides the programming data sequence using a Xilinx download cable, a third-party JTAG development system, JTAG-compatible board tester, or a simple microprocessor interface that emulates the JTAG instruction sequence.

All I/Os are 3-stated and pulled high by the bus-hold circuitry during in-system programming. If a particular signal must remain low during this time, then a pulldown resistor may be added to the pin.

External Programming

XC9500XL devices can also be programmed by the Xilinx HW-130 device programmer as well as third-party programmers. This provides the added flexibility of using pre-programmed devices during manufacturing, with an in-system programmable option for future enhancements and design changes.

Reliability and Endurance

All XC9500XL CPLDs provide a minimum endurance level of 10,000 in-system program/erase cycles and a minimum data retention of 20 years. Each device meets all functional, performance, and data retention specifications within this endurance limit.

IEEE 1149.1 Boundary-Scan (JTAG)

XC9500XL devices fully support IEEE 1149.1 boundary-scan (JTAG). EXTEST, SAMPLE/PRELOAD, BYPASS, USERCODE, INTEST, IDCODE, HIGHZ and CLAMP instructions are supported in each device. Additional instructions are included for in-system programming operations.

Design Security

XC9500XL devices incorporate advanced data security features which fully protect the programming data against unauthorized reading or inadvertent device erasure/reprogramming. **Table 3** shows the four different security settings available.

The read security bits can be set by the user to prevent the internal programming pattern from being read or copied. When set, they also inhibit further program operations but allow device erase. Erasing the entire device is the only way to reset the read security bit.

The write security bits provide added protection against accidental device erasure or reprogramming when the JTAG pins are subject to noise, such as during system power-up. Once set, the write-protection may be deacti-

vated when the device needs to be reprogrammed with a valid pattern with a specific sequence of JTAG instructions.

Table 3: Data Security Options

		Read Security	
		Default	Set
Write Security	Default	Read Allowed Program/Erase Allowed	Read Inhibited Program Inhibited Erase Allowed
	Set	Read Allowed Program/Erase Allowed	Read Inhibited Program/Erase Inhibited

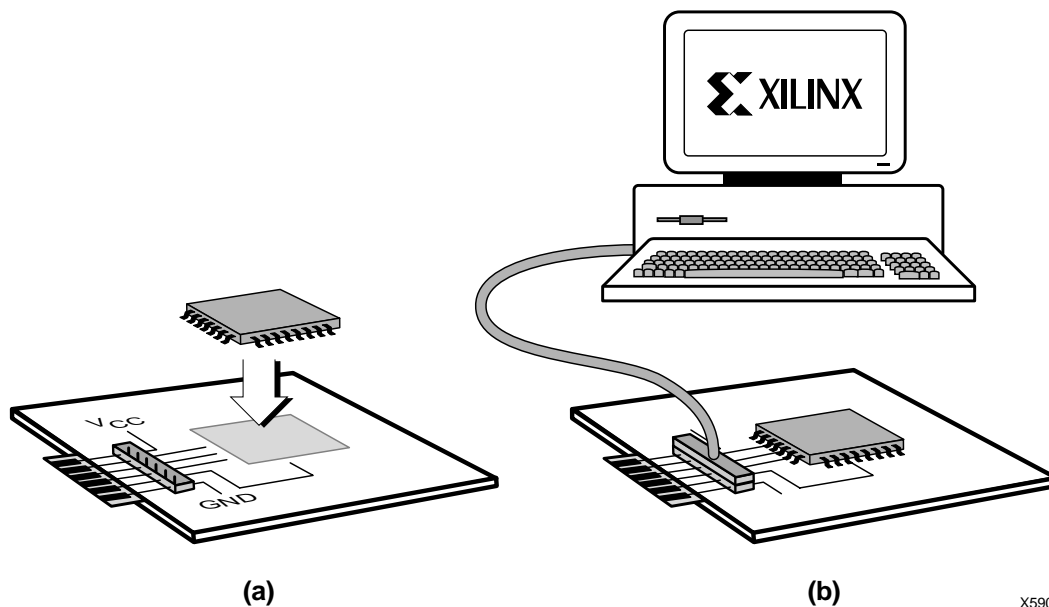

X5902

Figure 14: System Programming Operation (a) Solder Device to PCB and (b) Program Using Download Cable

Low Power Mode

All XC9500XL devices offer a low-power mode for individual macrocells or across all macrocells. This feature allows the device power to be significantly reduced.

Each individual macrocell may be programmed in low-power mode by the user. Performance-critical parts of the application can remain in standard power mode, while other parts of the application may be programmed for low-power operation to reduce the overall power dissipation. Macrocells programmed for low-power mode incur additional delay (t_{LP}) in pin-to-pin combinatorial delay as well as register setup time. Product term clock to output and product term output enable delays are unaffected by the macrocell power-setting. Signals switching at rates less than 50 ns rise/fall time should be assigned to the macrocells configured in low power mode.

Timing Model

The uniformity of the XC9500XL architecture allows a simplified timing model for the entire device. The basic timing model, shown in **Figure 15**, is valid for macrocell functions that use the direct product terms only, with standard power setting, and standard slew rate setting. **Table 4** shows how each of the key timing parameters is affected by the product term allocator (if needed), low-power setting, and slew-limited setting.

The product term allocation time depends on the logic span of the macrocell function, which is defined as one less than the maximum number of allocators in the product term path. If only direct product terms are used, then the logic span is 0. The example in **Figure 6** shows that up to 15 product terms are available with a span of 1. In the case of **Figure 7**, the 18 product term function has a span of 2.

Detailed timing information may be derived from the full timing model shown in Figure 16. The values and explanations

for each parameter are given in the individual device data sheets.

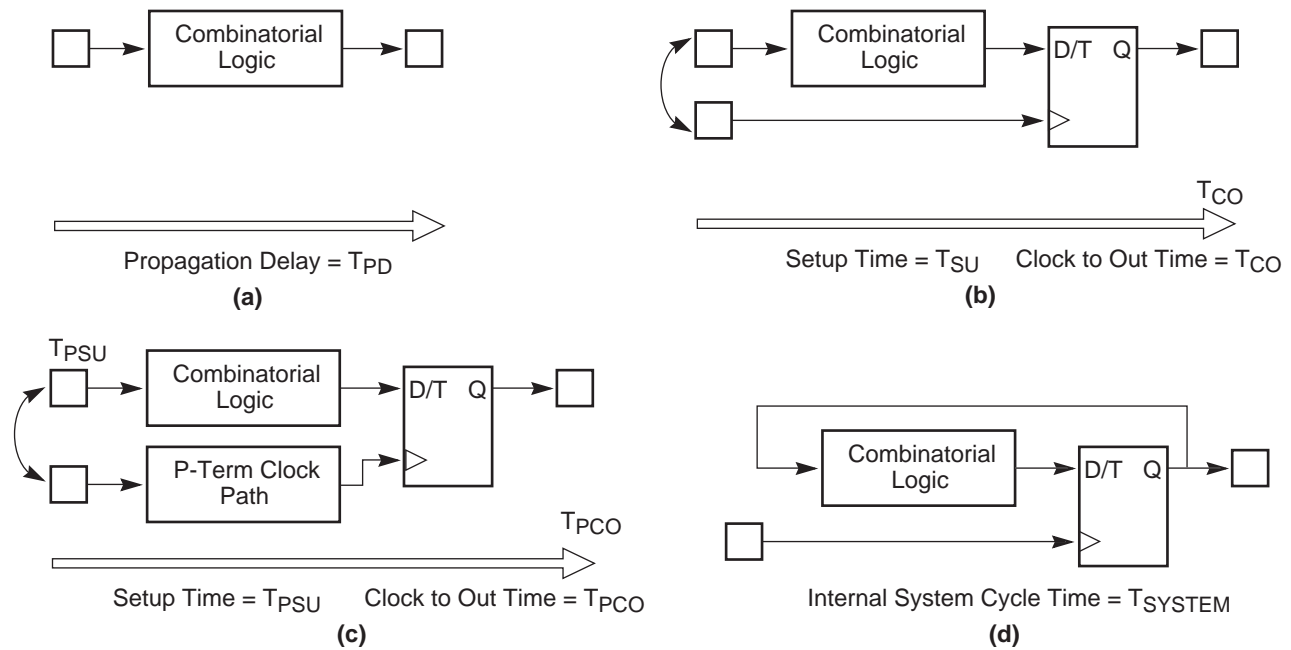

DS054_15_042101

Figure 15: Basic Timing Model

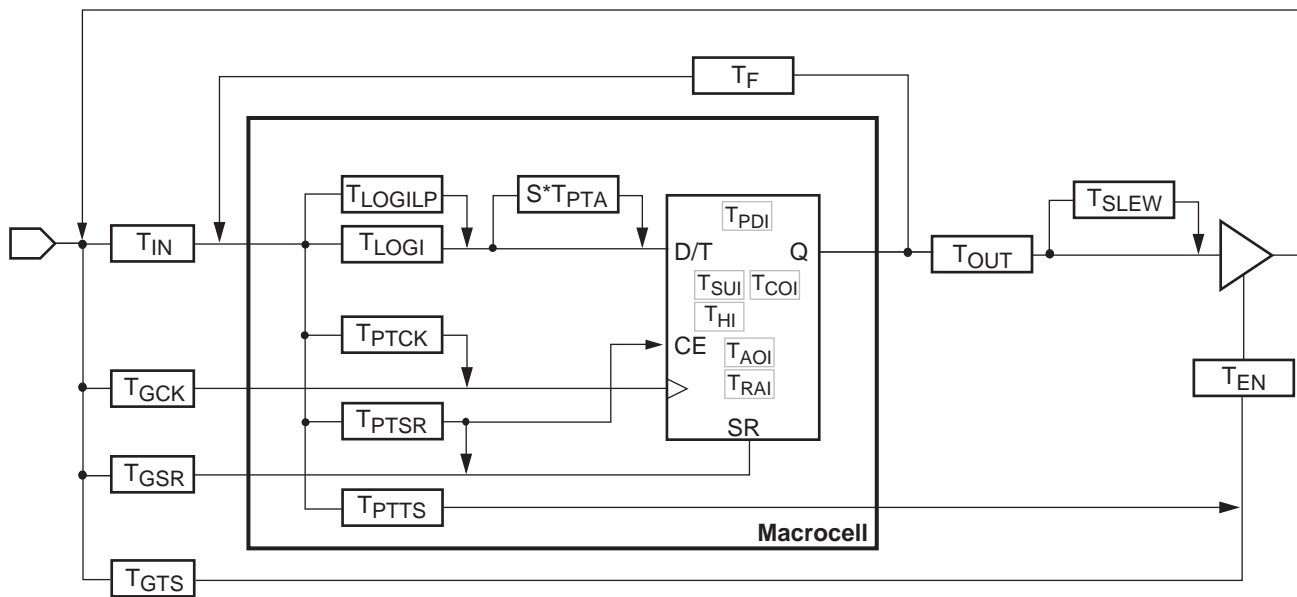

DS054_16_042101

Figure 16: Detailed Timing Model

Power-Up Characteristics

The XC9500XL devices are well behaved under all operating conditions. During power-up each XC9500XL device employs internal circuitry which keeps the device in the quiescent state until the V_{CCINT} supply voltage is at a safe level (approximately 2.5V). During this time, all device pins and JTAG pins are disabled and all device outputs are disabled with the pins weakly pulled high, as shown in Table 5. When the supply voltage reaches a safe level, all user registers become initialized (typically within 200 μ s), and the device is immediately available for operation, as shown in Figure 17.

If the device is in the erased state (before any user pattern is programmed), the device outputs remain disabled with weak pull-up. The JTAG pins are enabled to allow the device to be programmed at any time. All devices are shipped in the erased state from the factory.

If the device is programmed, the device inputs and outputs take on their configured states for normal operation. The JTAG pins are enabled to allow device erasure or boundary-scan tests at any time.

Development System Support

The XC9500XL family and associated in-system programming capabilities are fully supported in either software solutions available from Xilinx.

The Foundation Series is an all-in-one development system containing schematic entry, HDL (VHDL, Verilog, and

ABEL), and simulation capabilities. It supports the XC9500XL family as well as other CPLD and FPGA families.

The Alliance Series includes CPLD and FPGA implementation technology as well as all necessary libraries and interfaces for Alliance partner EDA solutions.

FastFLASH Technology

An advanced 0.35 micron feature size CMOS Flash process is used to fabricate all XC9500XL devices. The FastFLASH process provides high performance logic capability, fast programming times, and superior reliability and endurance ratings.

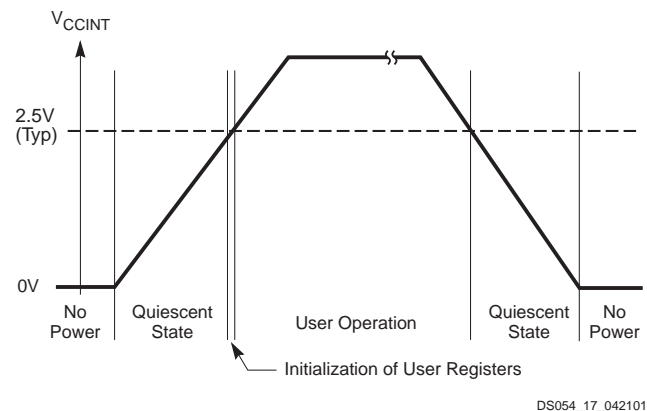

DS054_17_042101

Figure 17: Device Behavior During Power-up

Table 4: Timing Model Parameters

Parameter	Description	Product Term Allocator ⁽¹⁾	Macrocell Low-Power Setting	Output Slew-Limited Setting
T_{PD}	Propagation Delay	+ $T_{PTA} * S$	+ T_{LP}	+ T_{SLEW}
T_{SU}	Global Clock Setup Time	+ $T_{PTA} * S$	+ T_{LP}	-
T_{CO}	Global Clock-to-output	-	-	+ T_{SLEW}
T_{PSU}	Product Term Clock Setup Time	+ $T_{PTA} * S$	+ T_{LP}	-
T_{PCO}	Product Term Clock-to-output	-	-	+ T_{SLEW}
T_{SYSTEM}	Internal System Cycle Period	+ $T_{PTA} * S$	+ T_{LP}	-

Notes:

1. S = the logic span of the function, as defined in the text.

Table 5: XC9500XL Device Characteristics

Device Circuitry	Quiescent State	Erased Device Operation	Valid User Operation
IOB Bus-Hold	Pull-up	Pull-up	Bus-Hold
Device Outputs	Disabled	Disabled	As Configured
Device Inputs and Clocks	Disabled	Disabled	As Configured
Function Block	Disabled	Disabled	As Configured
JTAG Controller	Disabled	Enabled	Enabled

Further Reading

The following Xilinx links go to relevant XC9500XL CPLD documentation:

[Data Sheets, Application Notes, and White Papers.](#)

[Packaging](#)

[Online Store](#)

Revision History

The following table shows the revision history for this document.

Date	Version	Revision
09/28/98	1.0	Initial Xilinx release
10/02/98	1.1	Figure 1 correction
02/03/99	1.2	Included hot socket reference; revised layout; BGA package change for XC95288XL
04/02/99	1.3	Minor typesetting corrections.
06/07/99	1.4	Minor typesetting corrections.
06/07/99	1.5	Added CS280 package
01/25/02	1.6	Added DS054 data sheet number. Added 44-pin VQFP package. Updated Device Family table.
02/07/03	1.7	Added "Further Reading" section
08/02/04	1.8	Added Pb-free documentation
11/11/04	1.9	Changes to package designations in Table 2 on page 2.